

PANAGET

— Wood Flooring & Wall Panelling —



TECHNICAL LIST 2022



P. 12 French oak Tradition Saphir, Orféo 139



P. 16 French oak Tradition Sable, Alto 139x1210



P. 18 French oak Zenitude Café crème, Diva 139



P. 23 French oak Zenitude Tourbe, Diva 184



P. 26 French oak Authentic Bois flotté, Chevron 139

Laying systems



Unift Click:
Glue-free floating installation



2BeClick:
Glue-free floating installation



Floating glued installation



Glue down installation

Finishes



Matt lacquer
More info page 45



Satin lacquer
More info page 45



Oil
More info page 45

Compatibility with underfloor heating



Compatible with low-temperature
underfloor heating
More info page 40



Compatible with reversible underfloor
heating and cooling systems
More info page 41

TABLE OF CONTENTS



P. 28 French oak Authentic Natural oil, Sonate 140



P. 29 Teak, Ulysse 90



P. 37 French oak Vert cabane CBM 141

P. 6 GLOSSARY

- 6 Flooring Dimensions
- 8 Our Wood Grading
- 9 Bevels & Types of Finishes
- 9 Species
- 10 Finishes

P. 12 ENGINEERED TWO STRIP

- 12 Orféo 139 click / 11 mm
- 13 Orféo 139 click / 14 mm

P. 14 ENGINEERED SINGLE PLANKS

FIXED LENGTHS

- 14 Single plank 139 click Unifit / 12 mm

FINGER JOINTED LENGTHS:

- 15 Alto 139 and 184x2010 click Unifit / 12 mm
- 16 Alto 139x1210 click Unifit / 12 mm

RANDOM LENGTH & FIXED PACKING:

- 17 Diva 90 click / 12 mm
- 18 Diva 139 click / 12 mm
- 19 Diva 139 click / 14 mm
- 20 Diva 139 T&G / 14 mm
- 21 Diva 184 click / 12 mm
- 22 Diva 184 click / 14 mm
- 23 Diva 184 T&G / 14 mm
- 24 Diva 184 T&G / 15 mm
- 24 Diva 223 T&G / 15 mm

P. 25 PATTERNS

- 25 Herringbone 90 and 139
- 26 Chevron 90 and 139
- 27 Carmen

P. 28 SOLIDS

- 28 Sonate 90 and 140
- 29 Ulysse

P. 30 AGED FLOORING COLLECTIONS

- 30 Zenitude-Originé
- 31 Zenitude-Salvagio
- 31 Shabi

P. 32 ACCESSORIES

- 32 Laying accessories
- 33 Finishing accessories
- 35 Maintenance accessories

P. 36 CONCEPT BOIS MURAL (wall panelling)

- 36 Technical scheme
- 37 Wall panelling range

P. 38 ADVICE & TOOLS

- 38 Classes of use
- 39 Practical advice
- 40 Underfloor heating and cooling system
- 42 Fitting instructions
- 43 Discover the Panaget range
- 44 Care and cleaning
- 46 Expoz by Panaget
- 48 & 49 Guarantee and general terms of sale

P. 50 PANAGET COLOUR CHART

The 24 Panaget finishes



Technical specifications and performance statements for all products are available at: www.panaget.com



except Teak, Ulysse 90.



All French oak products except Oriféo 139 11 click, Sonate 90 and Sonate 140



For design, creation and manufacture, choose the French quality.

Flooring with a certified origin. 100% French oak offers superior mechanical properties, high density, incredible industrial adaptability, an international recognition... As such, there is no better choice. Genuine French oak from sustainably managed forests for nearly two centuries.

Panaget has been PEFC certified since 2002. All the PEFC certified products are indicated as such on our product sheets available and downloadable on our website www.panaget.com

Our quality department sets up quality processes at each production steps to never settle for the second best.

At Panaget, our flooring range and wall panelling products comply with all EU health and safety directives.

Your wood flooring or wall panelling will be a unique, one-off piece made with Panaget's signature care and attention to detail. This guarantee is our commitment to fully satisfy you. For more details, see page 48.



100% QUALITY

FOR YOUR PROJECT, CHOOSE PANAGET WOOD FLOORING & WALL PANELLING



SABLE
French oak | Authentic | Chevron 139 (page 26)

DESIGN

100% DESIGN



100% ECO-FRIENDLY



100% FRENCH OAK



FLOORING DIMENSIONS

BY PANAGET

Whether you are opting for engineered flooring or solid wood flooring, single plank or two-strip, make sure that you carefully measure the size of your room, the decor, the style that you want to achieve and then make your choice! The graphic below summarizes all the possible options!

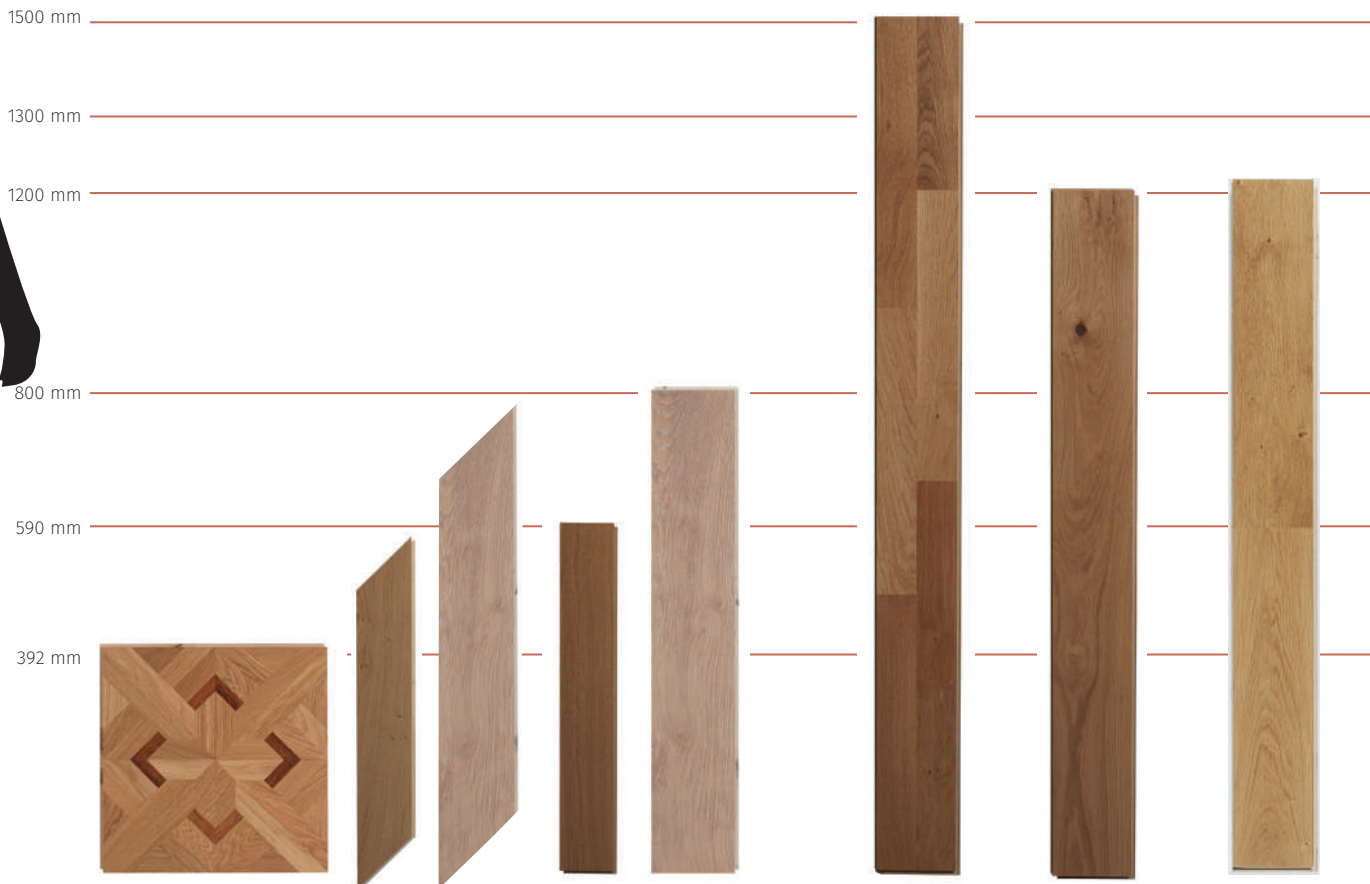

ENGINEERED WOOD FLOORING

	PATTERN				FIXED LENGTH		FINGER JOINT	
	Carmen	Chevron		Herringbone		Orféo	Single plank	Alto
Width	392	90	139	90	139	139	139	139
Length	392	589	789	590	800	1500	1210	1210

Page 27

Page 26

Page 25

Pages 12-13

Page 14

Page 16



ENGINEERED WOOD FLOORING

SOLID WOOD FLOORING

PARALLEL JOINTED

RANDOM LENGTHS & FIXED PACKING

Alto 139	184	Diva 90	Diva 139	Diva 184	Diva 223	Sonate 90 or 140	Width
2010	385-1180	495- 1992	500- 2000	495- 1992	500- 2000	400-1300	Length
Page 15	Page 17	Pages 18 to 20		Pages 21 to 24	Page 24	Page 28	



OUR WOOD GRADING

BY PANAGET



We never stand for the second best: we only use the best quality genuine French oak. Flooring with a certified origin. 100% French oak offers superior mechanical properties, high density, incredible industrial adaptability. As such, there is no better choice.

Wood is natural and has multiple peculiarities that is why we organize it by appearance. Find out more here about our 8 gradings on their unfinished aspect.

To sublimate them, we will carry out many operations (planing, sanding, brushing, etc.) before applying the finish that can be satin, matt or oiled.

Find out about the 24 shades on the colour chart on pages 50 and 51.

To know everything about our wood grading, scan this QR code.



Classic (Select): light and dark wood, black knots, medular rays, discolouration.



Authentic (Middle grade): light and dark wood, black knots, filled knots, partially opened knots, discolouration, black marks, cracks. The size of the knots is proportional to the width of the planks.



Tradition: light and dark wood, black knots, filled knots, partially opened knots, discolouration, black marks, filled cracks, sapwood.



Zenitude (Rustic): light and dark wood, black knots, filled knots, opened knots, discolouration, cracks, splits, sapwood. Grade with all the peculiarities of the wood without limitation.

The size of the knots is proportional to the width of the planks.

Zenitude is available in two other surface aspects:

- Origine (characterized by aged bevels) &
- Salvagio (characterized by structured, sometimes irregular facings).



Mix: light and dark wood, black knots, filled knots, opened knots, discolouration without limitation, cracks, splits, all sapwood allowed. Grade with all the peculiarities of the wood without limitation.

The size of the knots is proportional to the width of the planks.



Intenso: light and dark wood, black knots, filled knots, partially opened knots, all discolouration, cracks, sapwood without limitation, bluish sapwood. Grade with all the peculiarities of the wood without limitation.



BEVELS & TYPES OF FINISHES

BY PANAGET

The bevel is the border and edge of the plank, two planks cut together will leave a bevel in between. Cut at 45 degrees to the main face.

But that is not all: bevels are also decorative in order to highlight the width of the plank in your room.

Choose the bevels you like across all our ranges.

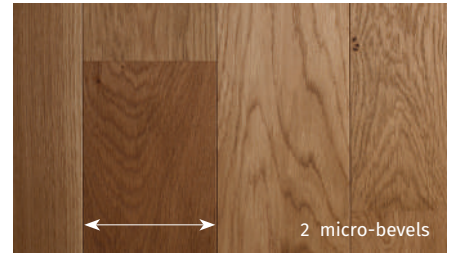

We apply three types of finishes on our floors:



Extra matt lacquer
More info page 45



Satin lacquer
More info page 45



Oil
More info page 45

SPECIES

BY PANAGET

Whether you choose a light or dark wood, the colour of your new wood floors will evolve over time as a result of exposure to UV light. You can see this natural oxydation by moving a rug or a piece of furniture covering the floor few weeks after it has been laid. The lighter area will take on the same colour as the rest of the wood floors within a few weeks. The uncovered part of the floor will come back to its original colour within a few weeks.



Origin: France
Light brown wood
Light and dark wood - knots
Available in all formats except Ulysse



Origin: Canada
Light to dark brown wood
Light and dark wood
Available as:
Diva 139 click, 12 mm
Diva 139 T&G, 14 mm



Origin: France
Flamed red wood
Light and dark wood - knots - all peculiarities accepted
Available as:
Diva 139 click, 14 mm

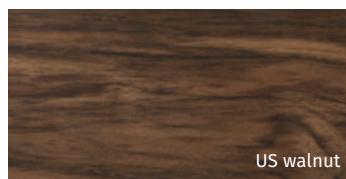

Origin: North America
Grey brown to dark brown wood
Light and dark wood - knots - sapwood
Available as:
Diva 139 click, 12 mm
Diva 139 T&G, 14 mm
Herringbone 139 T&G, 13 mm
- wood species sensitive to UV-light -



Origin: Indonesia
Yellowish brown to dark brown
Variation in colour from one strip to the next - quarter - sawn - knots - discolouration allowed
Available as:
Ulysse 90, 12 mm



FINISHES

BY PANAGET

Lacquer* or Oil? The choice is yours! Our finishes have all one thing in common: they bring out the natural character of the wood. Lacquered or oiled, our finishes always respect the wood beauty. Some specifications about our finishes below:

*Lacquer = Polyurethane

OUR COLLECTIONS

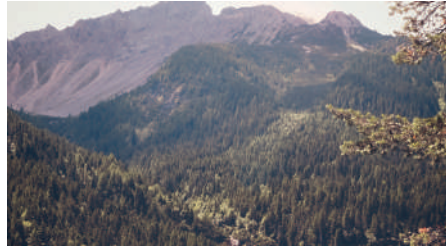

TIMELESS NATURAL HUES

DAYLIGHT WHITES

Extra matt lacquer



Our lacquer is extra matt. Our wood floors are covered by five to seven coats of Ecostrong lacquer in our factory. This factory-applied acrylic lacquer, UV-cured, contains corundum particles giving an ultra-hard surface.

Our high-quality state-of-the-art lacquered ensure effective protection against all wood floor's traditional enemies: abrasion, scratches, stains, etc. It is available in satin and matt versions.



BOIS FLOTTÉ

Brushed, matt lacquered with unfinish aspect



TOPAZE

Brushed, matt lacquered



MIEL

Brushed, natural matt lacquered



SAPHIR

Brushed, white matt lacquered



LINEN

Brushed, light white matt lacquered

Satin lacquer



SATIN

Unbrushed, satin lacquered



OPALE

Brushed, satin lacquered

Oil



Panaget oiled-floors are professionally UV-cured during the production process. This finish brings out the natural beauty of the wood and provides unique stains. When cared properly it will last for ever.

After installation, apply a thin coat of Panaget natural maintenance oil. Find our maintenance accessories page 35.



NATURAL OIL

Brushed, matt natural oiled



SABLE

Natural brushed, white patina matt oiled



SHABI CHAUX

Brushed, aged-finish white matt oiled



WHITE OIL

Brushed, white matt oiled



TUFEAU

Unbrushed chalk-tone matt oiled

Visualize each of our finishes in your interior, thanks to **Imagine by Panaget**.

To discover here:



SUBTLE GREYS



CAFÉ CRÈME

Brushed, coffee latte tone matt lacquered



TOPIA

Brushed, taupe-tone matt lacquered



ELEGANT BROWNS



ARGILE

Brushed, clay-tone matt lacquered



HABANO

Brushed, tobacco-leaf-tone matt lacquered

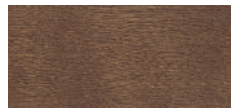

FAUVE

Brushed, brown satin lacquered

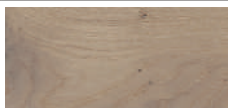

RAFIA

Brushed, raffia-tone matt oiled



GREY OIL

Brushed, grey matt oiled



CENDRE

Brushed, ash grey matt oiled



FLANELLE

Brushed, grey-brown-tone matt oiled

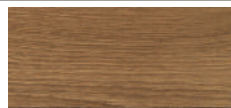

CUIR

Brushed, old leather-tone matt oiled



CUIVRE

Unbrushed, brown copper tone matt oiled



TOURBE

Brushed, dark brown-tone matt oiled

You can find the entire Panaget collection in the colour chart on pages 50 and 51.



ORFÉO 139 / 11mm CLICK

Engineered two strip to **fixed length**, HDF core - square edged
Made under the patent EN 13489



Species	Grade	Finishes	Lacquer	Oil	Bevel type	Class of use	Item number	Photo in the catalogue 2022-2023 or on
FRENCH OAK	classic (<i>select</i>)	bois flotté					1005781	panaget.com
	classic (<i>select</i>)	satin			square edged	23	1005771	panaget.com
	classic (<i>select</i>)	topaze					1005782	panaget.com
	tradition	sable*			square edged	23	1017894	panaget.com
	tradition	saphir					1006935	panaget.com
	tradition	satin			square edged	23	1006919	page 17

*While stocks last.

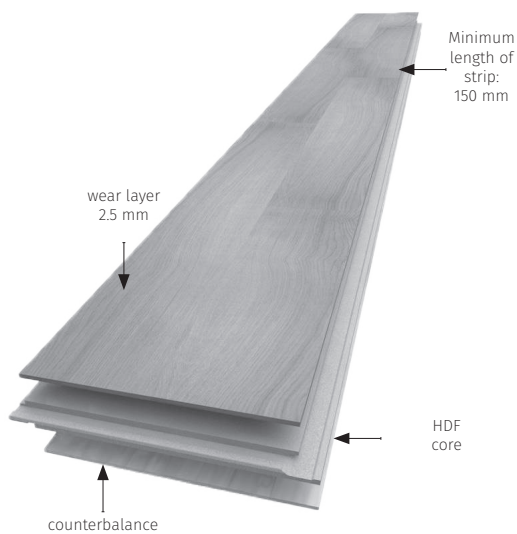

CHARACTERISTICS

Length	1500 mm
more details on pages 6 and 7	
Width	139 mm
Thickness	11 mm
Wear layer	2.5 mm
Core	HDF

PACKING

Weight / sqm	8.9 kg
Sqm / pack	1.67 (8 planks)
Pack / pallet	60
Sqm / pallet	100.20



- floating installation using plastic DPM + Isol 20
- or fully glue down using our special presto PM glue



fully glue down using our special presto PM glue





ORFÉO 139 / 14MM CLICK

Engineered two strip to **fixed length**, HDF core - square edged
Made under the patent EN 13489



Species	Grade	Finishes	Lacquer	Oil	Bevel type	Class of use	Item number	Photo in the catalogue 2022-2023 or on
FRENCH OAK	classic (select)	bois flotté					1005750	panaget.com
	classic (select)	satin			square edged	31	1005751	panaget.com
	tradition	cuir					1016636	panaget.com
	tradition	sable*			square edged	31	1017895	panaget.com
	tradition	saphir					1006929	panaget.com
	tradition	satin				square edged	31	1006920

*While stocks last.

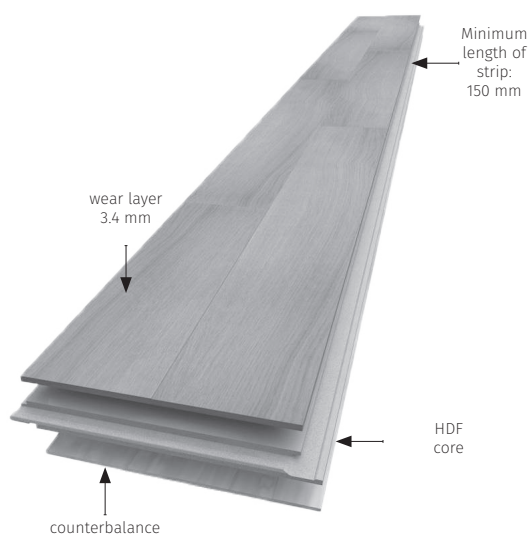

CHARACTERISTICS

Length	1500 mm
more details on pages 6 and 7	
Width	139 mm
Thickness	14 mm
Wear layer	3.4 mm
Core	HDF

PACKING

Weight / sqm	11.8 kg
Sqm / pack	1.46 (7 planks)
Pack / pallet	50
Sqm / pallet	73.00



- floating installation using plastic DPM + Isol 20
- or fully glue down using our special presto PM glue





SINGLE PLANK 139 / 12MM CLICK UNIFIT

Engineered to **fixed length**, HDF core - 2 bevels
Made under the patent EN 13489



Species	Grade	Finishes	Lacquer	Oil	Bevel type	Class of use	Item number	Photo in the catalogue 2022-2023 or on
Single plank 139								
FRENCH OAK	mix	bois flotté					1017681	panaget.com
	mix	linen					1017682	panaget.com
	mix	opale			2 bevels	23	1017683	panaget.com
	mix	topaze					1017684	panaget.com

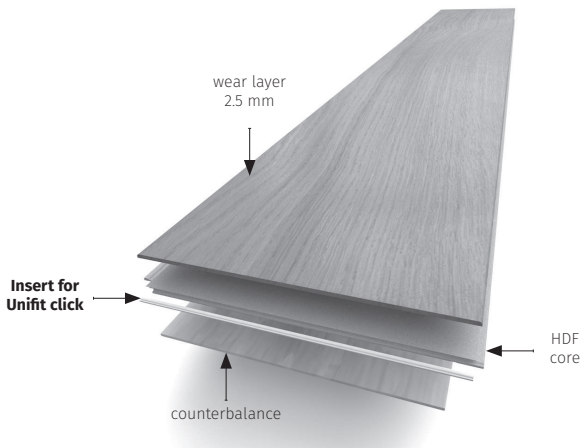

CHARACTERISTICS

Length	1210 mm
more details on pages 6 and 7	
Width	139 mm
Thickness	12 mm
Wear layer	2.5 mm
Core	HDF

PACKING

Weight / sqm	9.9 kg
Sqm / pack	1.85
Pack / pallet	45
Sqm / pallet	83.25



- floating installation using plastic DPM + Isol 20
- or fully glue down using our special presto PM glue



fully glue down using our special presto PM glue





ALTO 139 ou 184x2010 / 12MM CLIC UNIFIT

Engineered **twin & single-stave** plank, HDF core - 2 bevels
Made under the patent EN 13489



Species	Grade	Finishes	Lacquer	Oil	Bevel type	Class of use	Item number	Photo in the catalogue 2022-2023 or on
Alto 139x2010								
FRENCH OAK	mix	bois fotté			2 bevels	23	1017694	panaget.com
	mix	topaze					1017695	panaget.com

Species	Grade	Finishes	Lacquer	Oil	Bevel type	Class of use	Item number	Photo in the catalogue 2022-2023 or on
Alto 184x2010								
FRENCH OAK	mix	bois fotté			2 bevels	23	1018730	panaget.com
	mix	topaze					1018731	panaget.com

The finger-joint allows to simulate a real random length wood floor.

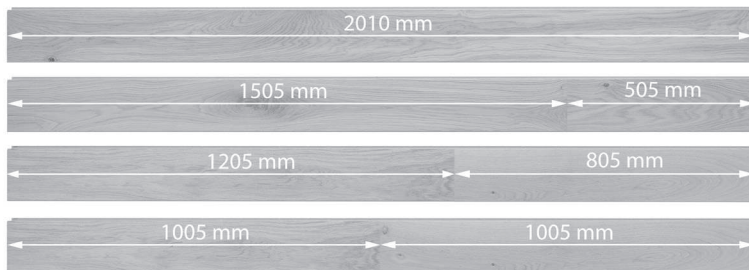

By order:
25% of full length planks
75% of finger-jointed planks

Package made up of 7 planks (1 plank can be replaced by 2 planks, equivalent to 2010 mm).
- 1505 + 505 mm
- 1205 + 805 mm
- 1005 + 1005 mm

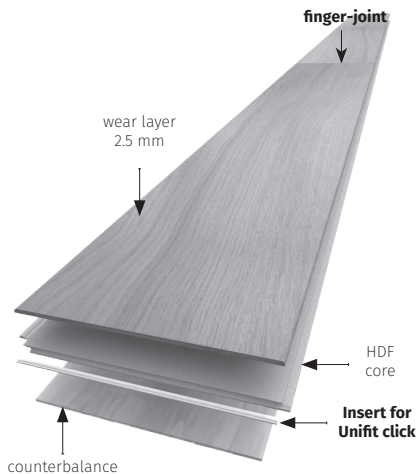

CHARACTERISTICS	139	184
Length more details on pages 6 and 7	2010 mm	2010 mm
Width	139 mm	184 mm
Thickness	12 mm	12 mm
Wear layer	2.5 mm	2.5 mm
Core	HDF	HDF
PACKING	139	184
Weight / sqm	9.9 kg	9.9 kg
Sqm / pack	1.96	1.85
Pack / pallet	45	48
Sqm / pallet	88.20	88.80



- floating installation using plastic DPM + Isol 20
- or fully glue down using our special presto PM glue



fully glue down using our special presto PM glue





ALTO 139x1210 / 12MM CLICK UNIFIT

Engineered **twin & single-stave** plank, HDF core - 2 bevels
Made under the patent EN 13489



Species	Grade	Finishes	Lacquer	Oil	Bevel type	Class of use	Item number	Photo in the catalogue 2022-2023 or on
FRENCH OAK	tradition	bois flotté					1017696	panaget.com
	tradition	café crème					1020643	panaget.com
	tradition	sable			2 bevels	23	1017896	page 29
	tradition	satín					1017699	panaget.com
	tradition	topaze					1017700	panaget.com
	zenitude (rustic)	shabi chaux				2 bevels	23	1017702

The finger-joint allows to simulate a real random length wood floor.

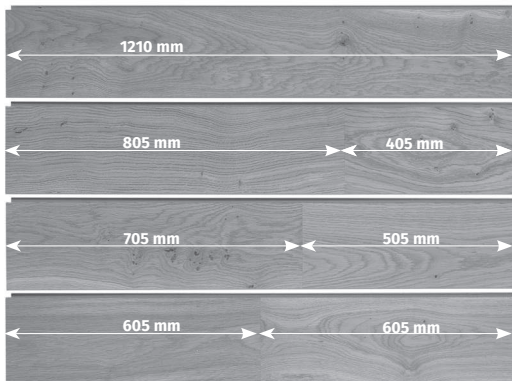

By order:
25% of full length planks
75% of finger-jointed planks

CHARACTERISTICS

Twin & single-stave length 1210 mm

- 1 plank = 1210 mm (25% full-length planks guarantee per pack)
- 1 plank = 805 + 405 mm
- 1 plank = 705 + 505 mm
- 1 plank = 605 + 605 mm

Width 139 mm

Thickness 12 mm

Wear layer 2.5 mm

Core HDF

PACKING

Weight / sqm 9.9 kg

Sqm / pack 1.85

Pack / pallet 45

Sqm / pallet 83.25

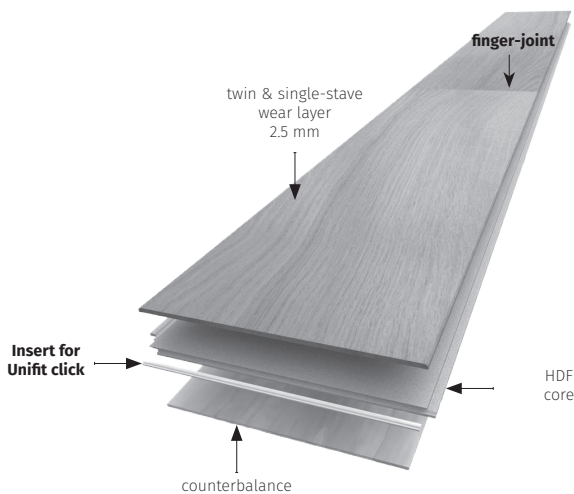

- floating installation using plastic DPM + Isol 20
- or fully glue down using our special presto PM glue



fully glue down using our special presto PM glue





DIVA 90 / 12MM CLICK

Engineered single plank to **random lengths**, HDF core - 4 bevels
Made under the patent EN 13489



Species	Grade	Finishes	Lacquer	Oil	Bevel type	Class of use	Item number	Photo in the catalogue 2022-2023 or on
FRENCH OAK	classic (select)	linen					1020641	panaget.com
	classic (select)	satin			4 bevels	23	1005768	panaget.com
	classic (select)	topaze					1005769	panaget.com
	authentic (middle grade)	cuir			4 bevels	23	1014174	panaget.com
	zenitude (rustic)	bois flotté			4 bevels		1015663	panaget.com

Single planks

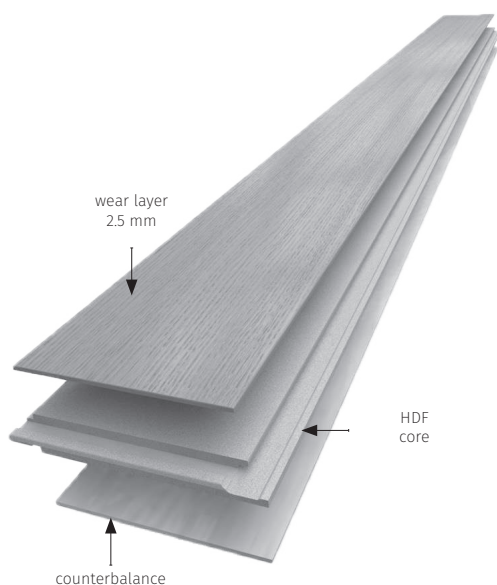

CHARACTERISTICS

Lengths more details on pages 6 and 7	385 to 1180 mm
Width	90 mm
Thickness	12 mm
Wear layer	2.5 mm
Core	HDF

PACKING

Weight / sqm	9.9 kg
Sqm / pack	1.47
Pack / pallet	44
Sqm / pallet	64.68



- floating installation
using plastic DPM + Isol 20
- or fully glue down using
our special presto PM glue



fully glue down using our
special presto PM glue





DIVA 139 / 12MM CLICK

Engineered wide single plank **random lengths**, HDF core - 4 bevels
Made under the patent EN 13489



Species	Grade	Finishes	Lacquer	Oil	Bevel type	Class of use	Item number	Photo in the catalogue 2022-2023 or on	
FRENCH OAK	classic (select)	bois flotté	☾				1005774	panaget.com	
	classic (select)	opale	☀		4 bevels	23	1005776	page 18	
	classic (select)	satin	☀				1005777	panaget.com	
	classic (select)	topaze	☾				1005764	panaget.com	
	authentic (middle grade)	bois flotté	☾				1017897	panaget.com	
	authentic (middle grade)	cuir		☾	☾		1014176	page 60	
	authentic (middle grade)	linen	☾			4 bevels	23	1000299	page 36
	authentic (middle grade)	miel	☾				1019167	panaget.com	
	authentic (middle grade)	topaze	☾				1000300	panaget.com	
	zenitude (rustic)	bois flotté	☾				1007643	page 13	
	zenitude (rustic)	café crème	☾				1019168	pages 46-47	
	zenitude (rustic)	linen	☾				1007649	pages 57	
	zenitude (rustic)	natural oil			☾		1007645	pages 34-35	
	zenitude (rustic)	rafia			☾	4 bevels	23	1007638	panaget.com
	zenitude (rustic)	sable			☾		1017898	panaget.com	
	zenitude (rustic)	tufeau			☾		1007639	panaget.com	
	zenitude (rustic)	white oil			☾		1007644	panaget.com	
	intenso	bois flotté	☾				1017017	pages 14-15	
	intenso	cuir			☾	4 bevels	23	1015661	panaget.com
	intenso	tufeau			☾		1015662	panaget.com	
Canadian maple*	satin		☀		4 bevels	23	1001177	panaget.com	
US walnut#	satin		☀		4 bevels	21	1001192	page 70	

*US walnut is very sensitive to UV-light causing colour variations over the years. It should therefore not be laid in front of large windows.
#Canadian maple is not compatible with heating/cooling system.

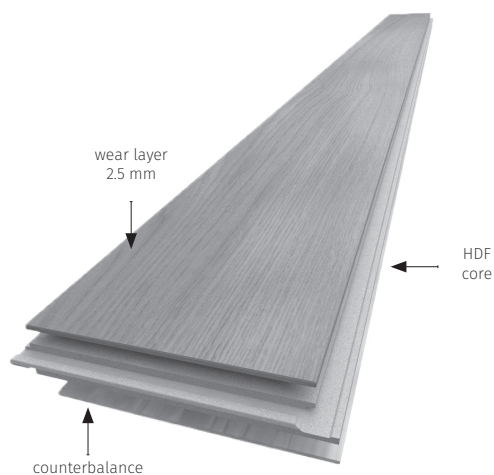

80% of the surface of the package is made with planks greater than 1m.

CHARACTERISTICS

Lengths	495 to 1992 mm
more details on pages 6 and 7	
Width	139 mm
Thickness	12 mm
Wear layer	2.5 mm
Core	HDF

PACKING

Weight / sqm	9.9 kg
Sqm / pack	1.38
Pack / pallet	65
Sqm / pallet	89.70



- floating installation using plastic DPM + Isol 20
- or fully glue down using our special presto PM glue



fully glue down using our special presto PM glue





DIVA 139 / 14MM CLICK

Engineered wide single plank **random lengths**, HDF core - 4 bevels
Made under the patent EN 13489



Species	Grade	Finishes	Lacquer	Oil	Bevel type	Class of use	Item number	Photo in the catalogue 2022-2023 or on	
FRENCH OAK	classic (<i>select</i>)	bois flotté					1019701	panaget.com	
	classic (<i>select</i>)	linen					1019702	panaget.com	
	classic (<i>select</i>)	opale			4 bevels	31	1006162	page 18	
	classic (<i>select</i>)	satin					1000553	panaget.com	
	classic (<i>select</i>)	topaze					1000554	panaget.com	
	authentic (<i>middle grade</i>)	bois flotté					1019700	panaget.com	
	authentic (<i>middle grade</i>)	cuir					1019704	page 60	
	authentic (<i>middle grade</i>)	miel				4 bevels	31	1019705	panaget.com
	authentic (<i>middle grade</i>)	saphir					1019706	page 33	
	authentic (<i>middle grade</i>)	topaze					1019703	panaget.com	
	authentic (<i>middle grade</i>)	tufeau					1019707	panaget.com	
	zenitude (<i>rustic</i>)	bois flotté					1019708	page 13	
	zenitude (<i>rustic</i>)	fauve				4 bevels	31	1019709	page 61
zenitude (<i>rustic</i>)	natural oil					1019710	panaget.com		
Flamed beech*		bois flotté					1019712	page 66	
		cuivre					1019714	pages 64-65	
		natural oil			4 bevels	31	1019713	page 67	
		satin					1019711	page 68	

*Beech is very sensitive to UV-light causing colour variations over the years. It should therefore not be laid in front of large windows.

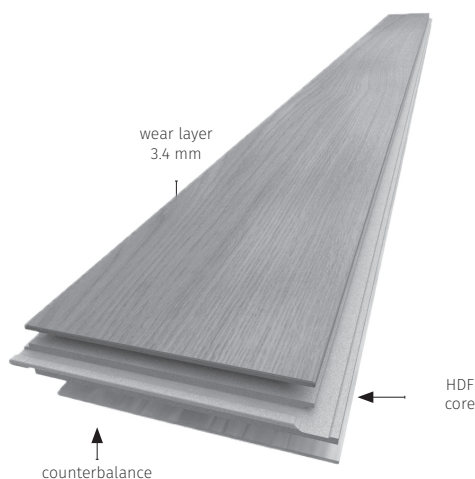

80% of the surface of the package
is made with planks greater than 1m.

CHARACTERISTICS

Lengths	495 to 1992 mm
more details on pages 6 and 7	
Width	139 mm
Thickness	14 mm
Wear layer	3.4 mm
Core	HDF

PACKING

Weight / sqm	11.6 kg
Sqm / pack	1.38
Pack / pallet	55
Sqm / pallet	75.90



- floating installation using plastic DPM + Isol 20
- or fully glue down using our special presto PM glue
For Flamed Beech, fully glue down only using our special presto PM glue





DIVA 139 / 14MM TONGUE & GROOVE

Engineered wide single plank **random lengths**, plywood core
Made under the patent EN 13489



Species	Grade - Surface aspects	Finishes	Lacquer	Oil	Bevel type	Class of use	Item number	Photo in the catalogue 2022-2023 or on
FRENCH OAK	classic (select)	bois flotté					1014261	panaget.com
	classic (select)	linen			4 bevels	31	1019715	panaget.com
	classic (select)	opale					1019716	page 18
	classic (select)	topaze					1019717	panaget.com
	classic (select)	satin			square edged		1005748	panaget.com
	authentic (middle grade)	topaze			4 bevels	31	1000297	panaget.com
	zenitude - salvagio	grey oil			2 bevels and sawing marks	31	1014171	page 51
	zenitude - salvagio	natural oil					1014172	page 25
	zenitude - origine	cuir					1006522	pages 58-59
	zenitude - origine	sable			2 aged bevels	31	1016633	panaget.com
zenitude - origine	tufeau					1006521	panaget.com	
Canadian maple*		satin			4 bevels	31	1001102	panaget.com
US walnut#		satin			4 bevels	22	1019718	page 70

*US walnut is very sensitive to UV-light causing colour variations over the years. It should therefore not be laid in front of large windows.
*Canadian maple is not compatible with heating/cooling system. // While stocks last.

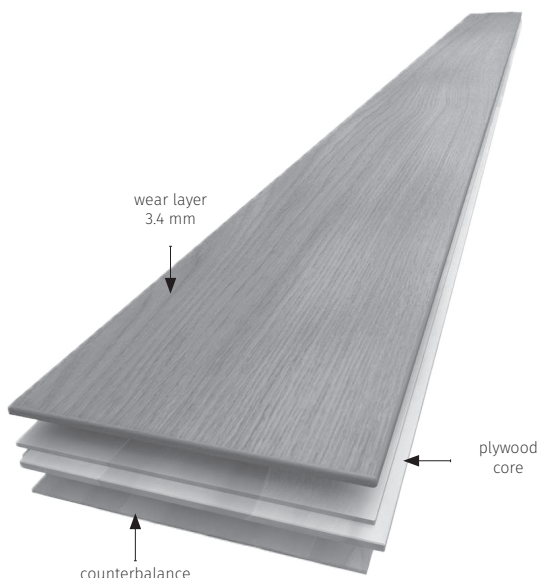

80% of the surface of the package
is made with planks greater than 1m.

CHARACTERISTICS

Lengths more details on pages 6 and 7	500 to 2000 mm
Width	139 mm
Thickness	14 mm
Wear layer	3.4 mm
Core	plywood

PACKING

Weight / sqm	7.4 kg
Sqm / pack	1.39
Pack / pallet	55
Sqm / pallet	76.45



- floating installation gluing
T&G and using plastic DPM
+ Isol 20
- or fully glue down using
our special presto PM glue





DIVA 184 / 12MM CLICK

Engineered extra-wide single plank **random lengths**, HDF core - 4 bevels
Made under the patent EN 13489



Species	Grade	Finishes	Lacquer	Oil	Bevel type	Class of use	Item number	Photo in the catalogue 2022-2023 or on
FRENCH OAK	classic (<i>select</i>)	bois flotté			4 bevels	23	1019817	page 12
	authentic (<i>middle grade</i>)	bois flotté					1000059	pages 10-11
	authentic (<i>middle grade</i>)	cuir					1014179	panaget.com
	authentic (<i>middle grade</i>)	opale			4 bevels	23	1000060	page 19
	authentic (<i>middle grade</i>)	topaze					1000061	panaget.com
	zenitude (<i>rustic</i>)	bois flotté					1016424	panaget.com
	zenitude (<i>rustic</i>)	flanelle					1007317	page 54
	zenitude (<i>rustic</i>)	linen					1007320	panaget.com
	zenitude (<i>rustic</i>)	rafia			4 bevels	23	1007318	page 50
	zenitude (<i>rustic</i>)	sable					1017917	page 30
zenitude (<i>rustic</i>)	tufeau					1007319	page 40	

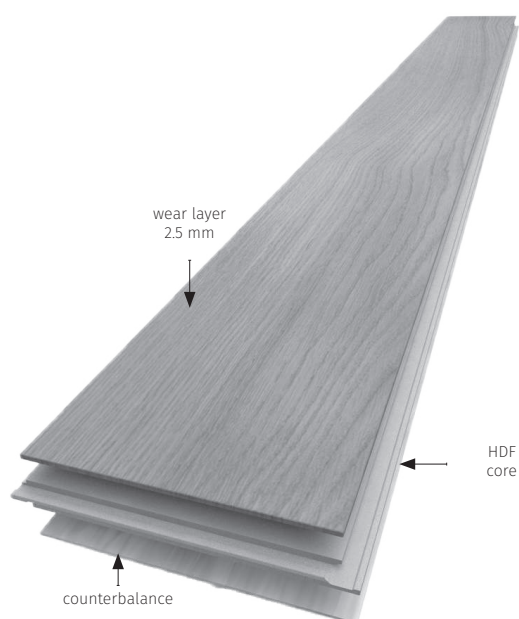

80% of the surface of the package is made with planks greater than 1m.

CHARACTERISTICS

Lengths	495 to 1992 mm
more details on pages 6 and 7	
Width	184 mm
Thickness	12 mm
Wear layer	2.5 mm
Core	HDF

PACKING

Weight / sqm	9.9 kg
Sqm / pack	2.20
Pack / pallet	40
Sqm / pallet	88



- floating installation using plastic DPM + Isol 20
- or fully glue down using our special presto PM glue



fully glue down using our special presto PM glue





DIVA 184 / 14MM CLICK

Engineered extra-wide single plank **random lengths**, HDF core - 4 bevels
Made under the patent EN 13489



Species	Grade	Finishes	Lacquer	Oil	Bevel type	Class of use	Item number	Photo in the catalogue 2022-2023 or on
FRENCH OAK	authentic <i>(middle grade)</i>	bois flotté			4 bevels	31	1016640	pages 12-13
	authentic <i>(middle grade)</i>	topaze					1000065	panaget.com
	intenso	bois flotté			4 bevels	31	1019818	panaget.com
	intenso	cuir					1020642	

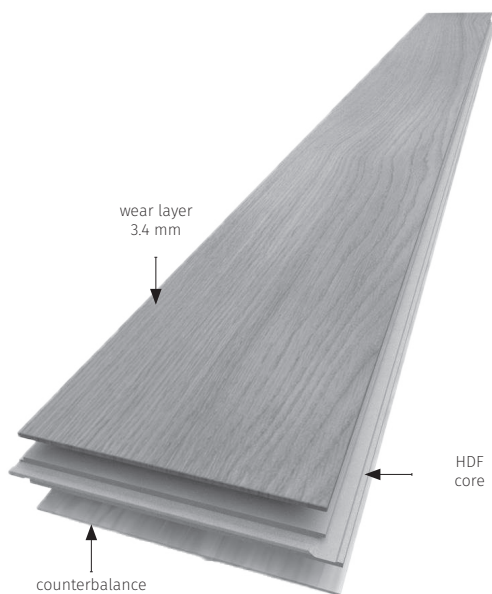

80% of the surface of the package is made with planks greater than 1m.

CHARACTERISTICS

Lengths	495 to 1992 mm
more details on pages 6 and 7	
Width	184 mm
Thickness	14 mm
Wear layer	3.4 mm
Core	HDF

PACKING

Weight / sqm	11.6 kg
Sqm / pack	1.83
Pack / pallet	40
Sqm / pallet	73.20



- floating installation using plastic DPM + Isol 20
- or fully glue down using our special presto PM glue





DIVA 184 / 14MM TONGUE & GROOVE

Engineered extra-wide single plank **random lengths**, plywood core
Made under the patent EN 13489



Species	Grade - Surface aspects	Finishes	Lacquer	Oil	Bevel type	Class of use	Item number	Photo in the catalogue 2022-2023 or on	
FRENCH OAK	classic (select)	bois flotté					1006159	page 12	
	classic (select)	satin			4 bevels	31	1006161	page 16	
	classic (select)	topaze					1006158	page 20	
	authentic (middle grade)	bois flotté					1016634	pages 10-11	
	authentic (middle grade)	cuir					1014166	panaget.com	
	authentic (middle grade)	miel			4 bevels	31	1019170	pages 26-27	
	authentic (middle grade)	saphir					1000069	panaget.com	
	authentic (middle grade)	topaze					1000070	panaget.com	
	zenitude (rustic)	argile#				2 bevels	31	1016189	page 56
	zenitude (rustic)	bois flotté					1007330	panaget.com	
	zenitude (rustic)	café crème					1019171	panaget.com	
	zenitude (rustic)	cendre					1016405	page 52	
	zenitude (rustic)	fauve					1016472	panaget.com	
	zenitude (rustic)	flanelle					1007324	page 54	
	zenitude (rustic)	grey oil					1007332	panaget.com	
	zenitude (rustic)	natural oil				4 bevels	31	1007333	panaget.com
	zenitude (rustic)	linen					1007314	panaget.com	
	zenitude (rustic)	rafa					1007325	page 50	
	zenitude (rustic)	sable					1019280	NEW page 30	
	zenitude (rustic)	topia					1007329	page 53	
	zenitude (rustic)	tourbe					1014165	page 62	
	zenitude (rustic)	tufeau					1007326	page 40	
	zenitude (rustic)	white oil					1007331	panaget.com	
	zenitude - origine	cuir					1006550	panaget.com	
	zenitude - origine	sable					1016635	panaget.com	
	zenitude - origine	tourbe				2 aged bevels	31	1006552	panaget.com
zenitude - origine	tufeau					1006551	pages 38-39		

*Argile is a tint that acts on wood's natural tannin properties to create an aged finish. In some cases, the shade may change slightly over time.

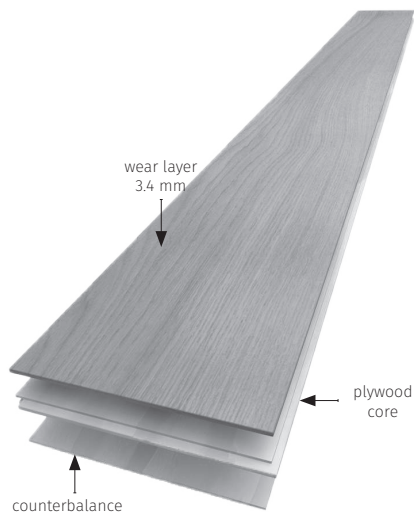

80% of the surface of the package is made with planks greater than 1m.

CHARACTERISTICS

Lengths	500 to 2000 mm
more details on pages 6 and 7	
Width	184 mm
Thickness	14 mm
Wear layer	3.4 mm
Core	plywood

PACKING

Weight / sqm	7.4 kg
Sqm / pack	1.84
Pack / pallet	44
Sqm / pallet	80.96



- floating installation gluing T&G and using plastic DPM + Isol 20
- or fully glue down using our special presto PM glue





DIVA 184 OR 223 / 15MM TONGUE & GROOVE

Engineered extra-wide single plank **random lengths**, plywood core, 4 bevels
Made under the patent EN 13489



Species	Grade	Finishes	Lacquer	Oil	Bevel type	Class of use	Item number	Photo in the catalogue 2022-2023 or on
DIVA 184								
FRENCH OAK	authentic (middle grade)	bois flotté			4 bevels	33	1014181	pages 10-11
	authentic (middle grade)	cuir					1014182	panaget.com
	authentic (middle grade)	flanelle					1014183	panaget.com
	authentic (middle grade)	rafia					1014184	pages 48-49
	authentic (middle grade)	topaze					1014180	panaget.com
	authentic (middle grade)	tufeau					1014185	page 37

Species	Grade	Finishes	Lacquer	Oil	Bevel type	Class of use	Item number	Photo in the catalogue 2022-2023 or on
DIVA 223								
FRENCH OAK	authentic (middle grade)	argile			2 bevels	33	1017303	panaget.com
	authentic (middle grade)	bois flotté					1016985	panaget.com
	authentic (middle grade)	sable					1017302	panaget.com
	authentic (middle grade)	topaze					1016986	pages 22-23

4.5 mm extra-thick wear layer for commercial use (class 33).

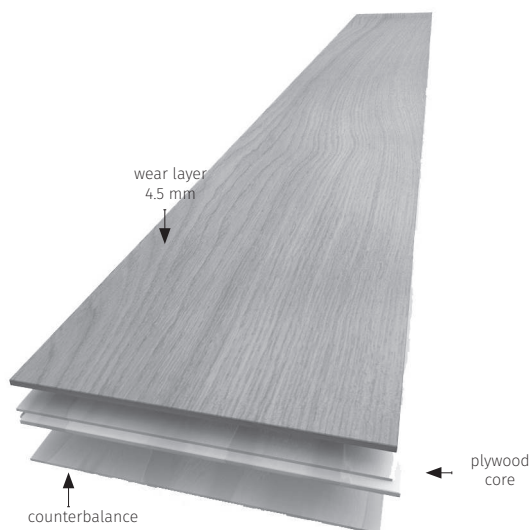

CHARACTERISTICS	184	223
Lengths more details on pages 6 & 7	500 to 2000 mm	2000 mm
Width	184 mm	223 mm
Thickness	15 mm	
Wear layer	4.5 m	
Core	plywood	birch plywood
PACKING	184	223
Weight / sqm	7.9 kg	10.9 kg
Sqm / pack	1.84	1.78
Pack / pallet	44	39
Sqm / pallet	80.96	69.42



fully glue down using our special presto PM glue



Except Diva 223 ranked A

184: 80% of the planks are 1 m long and over.
223: Minimum of three 2m long planks per pack. The 4th plank is either 700+1300mm or 1000+1000mm or 2000m.



HERRINGBONE 90 OR 139 / TONGUE & GROOVE

Engineered single plank, herringbone pattern, 4 bevels
Made under the patent EN 13489



Species	Grade	Finishes	Lacquer	Oil	Bevel type	Class of use	Item number	Photo in the catalogue 2022-2023 or on
Herringbone 90								
FRENCH OAK	mixed classic/authentic	habano	☾				1016742	panaget.com
	mixed classic/authentic	linen	☾				1005924	page 72
	mixed classic/authentic	satin	☀		4 bevels	23	1016745	panaget.com
	mixed classic/authentic	topaze NEW	☾				1020644	panaget.com
	mixed classic/authentic	tufeau		👉			1016743	panaget.com

Species	Grade - Surface aspects	Finishes	Lacquer	Oil	Bevel type	Class of use	Item number	Photo in the catalogue 2022-2023 or on
Herringbone 139								
FRENCH OAK	authentic (middle grade)	bois flotté	☾				1016617	page 73
	authentic (middle grade)	miel	☾		4 bevels	31	1019172	panaget.com
	authentic (middle grade)	topaze	☾				1016618	pages 74-75
	zenitude (rustic)	bois flotté	☾		4 bevels	31	1019173	panaget.com
	zenitude - origine	flanelle		👉			1007655	panaget.com
	zenitude - origine	shabi chaud		👉	4 with 2 aged	31	1015715	panaget.com
	zenitude - origine	tufeau		👉			1007658	panaget.com
US walnut#		satin	☀		4 bevels	21	1019564	pages 76-77

#US walnut is very sensitive to UV-light causing colour variations over the years. It should therefore not be laid in front of large windows.

Herringbone 90

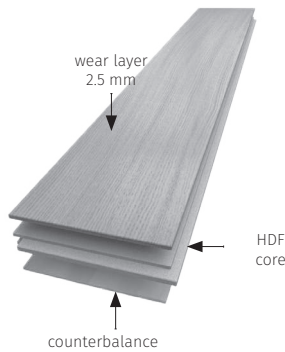

Herringbone 139

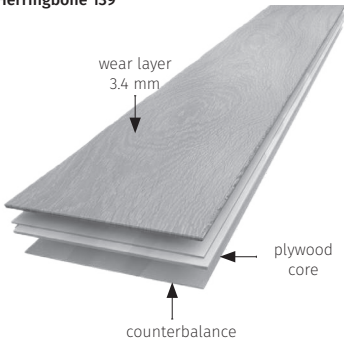

Herringbone

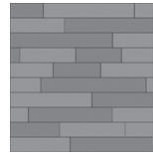

English style

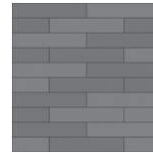

Brick effect

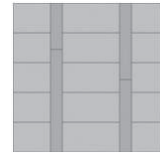

Ladder effect

CHARACTERISTICS	HB 90	HB 139 / Walnut
Length more details on pages 6 & 7	590 mm	800 mm
Width	90 mm	139 mm
Thickness	12 mm	14 mm / 13 mm
Wear layer	2.5 mm	3.4 mm / 2.5 mm
Core	HDF	plywood

Only Walnut Herringbone 139 is 13mm thick with a wear layer of 2.5mm.

PACKING	HB 90	HB 139 / Walnut
Weight / sqm	9.9 kg	7.4 kg
Sqm / pack	1.91	2.22 / 2.45
Pack / pallet	32	32
Sqm / pallet	61.12	71.04 / 78.40



- floating installation gluing T&G and using plastic DPM + Isol 20
- or fully glue down using our special presto PM glue



- in 90, fully glue down using our special presto PM glue
- in 139, not compatible





CHEVRON 90 OR 139 / 14MM TONGUE & GROOVE

Engineered single plank, chevron pattern, plywood core, 4 bevels
Made under the patent EN 13489



Species	Grade	Finishes	Lacquer	Oil	Bevel type	Class of use	Item number	Photo in the catalogue 2022-2023 or on
Chevron 90								
FRENCH OAK	classic (select)	satin			4 bevels	31	1005742	panaget.com
	classic (select)	topaze			4 bevels	31	1005735	panaget.com
	authentic (middle grade)	bois flotté			4 bevels	31	1019719	panaget.com
	zenitude (rustic)	tufeau			4 bevels	31	1019720	page 78

Species	Grade	Finishes	Lacquer	Oil	Bevel type	Class of use	Item number	Photo in the catalogue 2022-2023 or on
Chevron 139								
FRENCH OAK	authentic (middle grade)	bois flotté			4 bevels	31	1019821	page 79
	authentic (middle grade)	café crème			4 bevels	31	1019822	pages 80-81
	authentic (middle grade)	sable			4 bevels	31	1019823	panaget.com
	zenitude (rustic)	miel			4 bevels	31	1019824	page 82

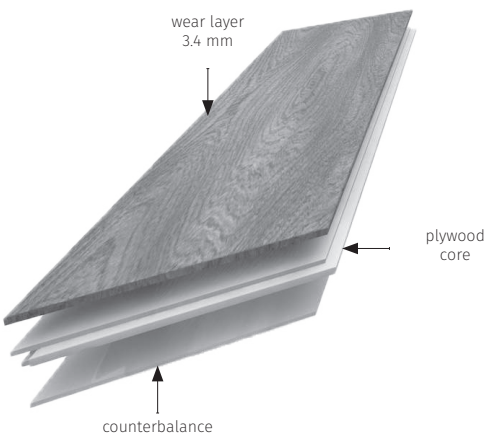
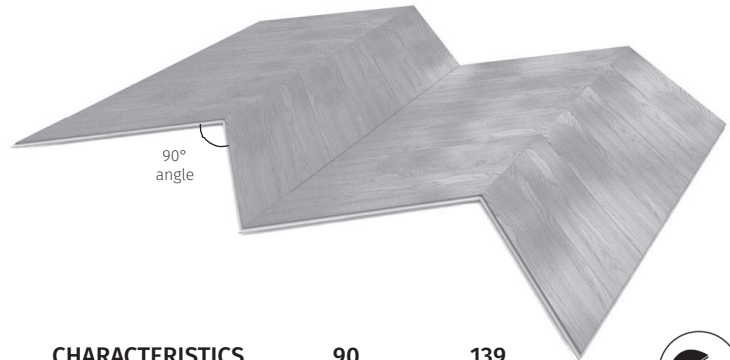
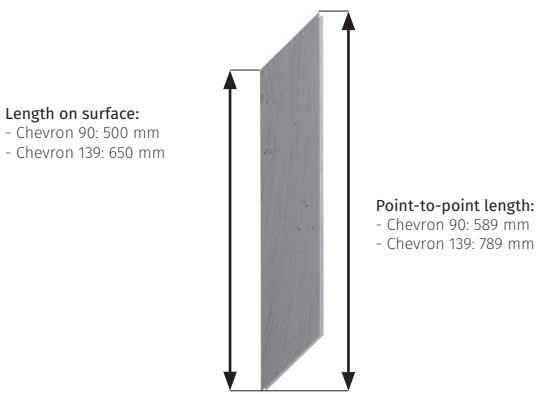

CHARACTERISTICS	90	139
Lengths more details on pages 6 & 7	500 mm	650 mm
Point-to-point length	589 mm	789 mm
Width	90 mm	139 mm
Thickness	14 mm	
Wear layer	3.4 mm	
Core	plywood	

PACKING	90	139
Weight / sqm	7.4 kg	7.4 kg
Sqm / pack	1.26	1.45
Pack / pallet	32	32
Sqm / pallet	40.32	46.40



- floating installation
gluing T&G and using
plastic DPM + Isol 20
- or fully glue down using
our special presto PM glue





CARMEN / 14MM TONGUE & GROOVE

A unique engineered hand-made marquetry panel format, plywood core, square edged
Made under the patent EN 13489



Species	Grade	Finishes	Lacquer	Bevel type	Class of use	Item number	Photo in the catalogue 2022-2023 or on
FRENCH OAK	classic (<i>select</i>)	satin n°1				1005715	panaget.com
	classic (<i>select</i>)	satin n°2		square edged	31	1005714	panaget.com
	classic (<i>select</i>)	satin n°5				1005712	page 90

You can border Carmen panels with **square edged** Diva 139 planks.

FRENCH OAK	classic (<i>select</i>)	satin		square edged	31	1005748	panaget.com
------------	---------------------------	-------	--	--------------	----	---------	-------------

This parquet is hand-made and may not be perfectly centered.

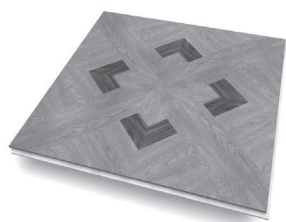

CARMEN N°1
Merbau inlays

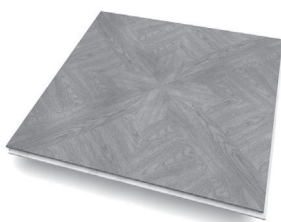

CARMEN N°2



CARMEN N°5

CHARACTERISTICS

Length	392 mm
more details on pages 6 and 7	
Width	392 mm
Thickness	14 mm
Wear layer	3.2 mm
Core	plywood

PACKING

Weight / sqm	10.8 kg
Sqm / pack	1.23 (8 tiles)
Pack / pallet	42
Sqm / pallet	51.66



- floating installation
gluing T&G and using
plastic DPM + Isol 20
- or fully glue down using
our special presto PM glue
(preferred)

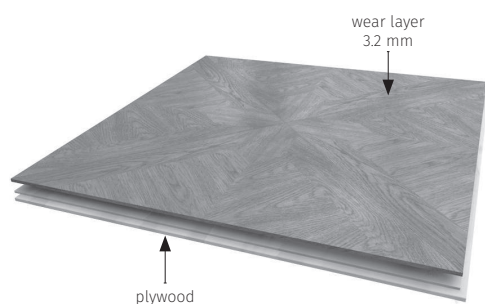



SONATE 90 OR 140 / 14 MM TONGUE & GROOVE

Solid single plank, 4 bevels
Made under the patent EN 13226



Species	Grade	Finishes	Lacquer	Oil	Bevel type	Class of use	Item number	Photo in the catalogue 2022-2023 or on
Sonate 90								
FRENCH OAK	authentic (middle grade)	natural oil					1000026	panaget.com
	authentic (middle grade)	satin			4 bevels	34	1000027	panaget.com
	authentic (middle grade)	topaze					1000028	page 21
	zenitude (rustic)	bois flotté			4 bevels	34	1007293	panaget.com
	zenitude (rustic)	miel					1020645	panaget.com

Species	Grade - Surface aspects	Finishes	Lacquer	Oil	Bevel type	Class of use	Item number	Photo in the catalogue 2022-2023 or on
Sonate 140								
FRENCH OAK	classic (select)	topaze			4 bevels	34	1017918	panaget.com
	authentic (middle grade)	natural oil					1000033	page 24
	authentic (middle grade)	saphir			4 bevels	34	1000031	panaget.com
	authentic (middle grade)	topaze					1000034	panaget.com
	zenitude (rustic)	bois flotté					1007261	panaget.com
	zenitude (rustic)	café crème			4 bevels	34	1019819	panaget.com
	zenitude (rustic)	linen					1007268	panaget.com
	zenitude (rustic)	miel					1019820	page 28
	zenitude - origine	cuir				4 bevels with 2 aged	34	1006531
zenitude - origine	sable						1017920	panaget.com

Sonate 90

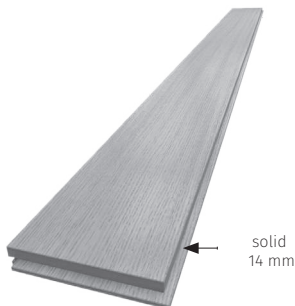

Sonate 140

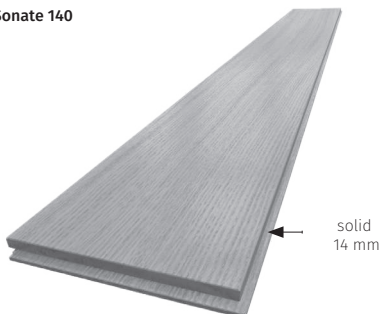
**CHARACTERISTICS**

	Sonate 90	Sonate 140
Length	400 to 1300 mm	400 to 1300 mm
more details on pages 6 & 7	Except Origine 500 to 1300 mm	
Width	90 mm	140 mm
Thickness	14 mm	14 mm
Wear layer	7 mm	7 mm

PACKING

	Sonate 90	Sonate 140
Weight / sqm	10.7 kg	10.7 kg
Sqm / pack	1.64	1.64
Pack / pallet	32	40
Sqm / pallet	52.48	65.60



fully glue down using our special presto PM glue





ULYSSE / 12MM TONGUE & GROOVE

Solid single plank boat deck
Made under the patent EN 13226

Species	Finishes	Oil	Bevel type	Class of use	Item number	Photo in the catalogue 2022-2023
Teak	pre-oiled*		square edged	22	1019688	page 78
Maintenance	natural oil in bottle		1 liter / 100 sprays		1001885	

*After installation, apply a thin coat of Panaget natural maintenance oil.

Boat deck wood floors
dedicated to bathrooms and wet areas.

Not compatible with stagnant water. Do not use inside the shower or outside the pool.

CHARACTERISTICS

Lengths	300 to 1200 mm
Width	90 mm
Thickness	12 mm
Wear layer	4 mm

PACKING

Weight / sqm	8.4 kg
Sqm / pack	1.51
Pack / pallet	44
Sqm / pallet	66.44



fully glue down using our special presto PM glue



fully glue down using our special presto PM glue

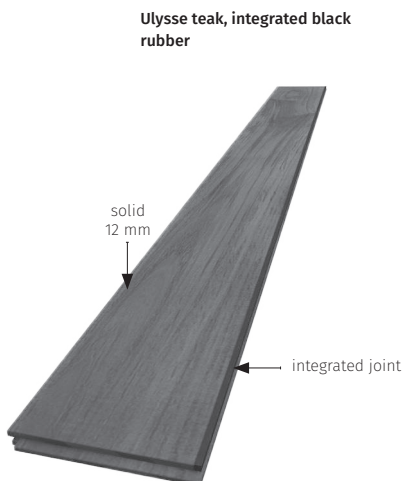



AGED FLOORING

BY PANAGET



ZENITUDE-ORIGINE

The aged look of the Origine aspect is inspired by the raw, natural beauty of oak. The strips are chosen at the sawmill for their peculiarities (knots, cracks, colour variation...) developed over the oaks growth.

Each strip is **bevelled lengthwise using traditional aging techniques**, brushed to highlight the uniqueness of the wood, and to give a simple, silky oil finish.

Species	Formats	Grade	Finishes	Oil	Bevel type	Class of use	Item number	Photo in the catalogue 2022-2023 or on	
FRENCH OAK	Diva 139/14 tongue & groove*	zenitude - origine	cuir	●			1006522	pages 58-59	
		zenitude - origine	sable	●	2 aged bevels	31	1016633	panaget.com	
		zenitude - origine	tufeau	●			1006521	panaget.com	
	Diva 184/14 tongue & groove*	zenitude - origine	cuir	●				1006550	panaget.com
		zenitude - origine	sable	●	2 aged bevels	31	1016635	panaget.com	
		zenitude - origine	tourbe	●			1006552	panaget.com	
		zenitude - origine	tufeau	●			1006551	pages 38-39	
	Herringbone 139*	zenitude - origine	flanelle	●				1007655	panaget.com
		zenitude - origine	shabi chaux	●	2 aged bevels	31	1015715	panaget.com	
		zenitude - origine	tufeau	●			1007658	panaget.com	
	Sonate 140/14 (solid)*	zenitude - origine	cuir	●	4 with 2 aged	34	1006531	panaget.com	
		zenitude - origine	sable	●			1017920	panaget.com	

* You can find the technical specification of the Zenitude-Origine collection here:
Diva 139/14 on page 20 / Diva 184/14 on page 23 / Herringbone 139 on page 25 / Sonate 140 on page 28



Planks especially selected for their distinguishing features ●

Deeply brushed ●

Aged bevels ●



AGED FLOORING

BY PANAGET



ZENITUDE-SALVAGIO

When we say our flooring is aged, we actually mean it. The distinctive, **rough-cut look** of the **Salvagio** aspect is achieved by carefully selecting the boards in our workshops: they come in different thicknesses, completed with saw marks, discolorations, cracks and tannin marks. These **natural features** give a blend of elegance, character, and vintage appeal.

The planks are brushed to give a traditional look along with a silky oil finish.

Species	Formats	Grade	Finishes	Oil	Bevel type	Class of use	Item number	Photo in the catalogue 2022-2023
FRENCH OAK	Diva 139/14 tongue & groove*	zenitude - salvagio	grey oil		2 bevels and sawing marks	31	1014171	page 51
		zenitude - salvagio	natural oil				1014172	page 25

* You can find the technical specification of the Zenitude-Salvagio collection here:
Diva 139/14 on page 20



SHABI

Based on our advanced manufacturing expertise, we have accurately reproduced the faded appearance of aged flooring, as well as preserve...
Shabi: a uniquely original reminder that time never stands still.

Species	Formats	Grade	Finishes	Oil	Bevel type	Class of use	Item number	Photo in the catalogue 2022-2023 or on
FRENCH OAK	Alto 139x1210 12 click Unifit*	zenitude	shabi chaux		2 bevels	23	1017702	page 32
	Herringbone 139*	zenitude - origine	shabi chaux		2 aged bevels	31	1015715	panaget.com

* You can find the technical specification of the Shabi collection here:
Alto 139x1210 on page 16 / Herringbone 139 on page 25

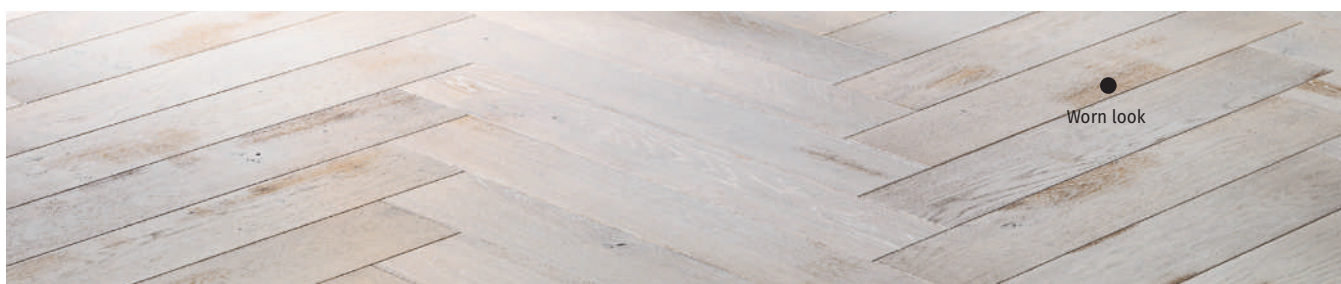



LAYING

ACCESSORIES

Get the job off to a good start with our laying accessories!
You need the right information, the right tools and to be well-prepared.
To ensure wood floor is durable and stable, it needs to be laid under the right conditions.

Installation accessories

	description	item number
Laying kit	wedge spacers, pull bar, tapping block	1001864
Professional pull bar	2 kg	1001708
B3 trowel	4 x 4 mm notched, stainless steel	1001870

Underlays

	description	item number
ISOL 20 - for underfloor heating	roll of 25 sqm thickness 2 mm	1001662
ISOL 30 - for sound insulation	roll of 15 sqm integrated damp proof membrane (200 µ) thickness 3 mm	1001661
ISOL 40 - for wood floor to fully glue down	roll of 15 sqm (1 m x 15 m) thickness 2 mm	1014106

Special wood flooring glues

		consumption	item number
PRESTO BIB	sold per unit	10 to 15 sqm / bottle	1001658
PRESTO GUN	sold per unit	12 to 15 ml / unit 310 ml cartridge	1001656
Compulsory for reversible underfloor heating system	PRESTO PM#	7,5 kg packet	1017921
		2 packets / bucket = 15 kg	1017922
Spatula	4 x 4 - B3 trowel - wood handle - steel blade		1001870



*Remember to order the 4x4 spatula - B3 trowel for wood flooring to apply our presto PM glue.



FINISHING

ACCESSORIES

Enhance your room with our finishing accessories!

The accessories you choose can be almost as important as the type of wood floor you go for. The right finishing can really make a difference to perfect your room.

Skirting boards

*Also suitable for the finishes mentioned

dimensions mm
h x L x t

quantity sold only
per pack#

item number

Veneered grooved end mdf core

		dimensions mm h x L x t	quantity sold only per pack#	item number	
Subject to availability 	French oak others species	argile (topia)	78 x 2200 x 14	1016625	
		tourbe (cuivre)		1002064	
		bois flotté		1020395	
		café crème		1020399	
		cuir		1020401	
		grey	80 x 2200 x 14 	1020400	
		sable		6 / pack Per complete pack only	1020398
		topaze		1020394	
		tufeau		1020390	
		*dark brown (fauve, walnut)		1002079	
		linen		1002080	
		*saphir (chaux, white oil)		1001950	
		*satin (opale, natural oil, miel)	80 x 2200 x 13	1002083	
		beech		1002049	
*red exo (teak)		1002001			

Veneered, wooden core moulding, grooved end

		100 x 2200 x 13	6 / pack Per complete pack only	1002061
--	--	-----------------	------------------------------------	---------

White ready to be painted

		58 x 2200 x 13	6 / pack Per complete pack only	1014190
		80 x 2200 x 13		1001991

Non-lacquered French oak

		80 x 2200 x 14 	6 / pack Per complete pack only	1020389
--	--	--------------------	------------------------------------	---------

PRESTO GUN

sold per unit

12 to 15 ml /
unit 310 ml cartridge

1001656

For a perfect harmony with our oiled wood floors, choose the unfinished skirting board and then use our stained oil bottles (see page 37) or choose the white skirting board ready to paint.

Remember to order the Presto Gun glue (cf. page 32) to glue your skirtings boards.



FINISHING

ACCESSORIES

Finishing profiles



quadrant



scotia

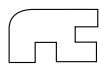

stair nosing



radiator collar

		dimensions mm h x l x L	quantity sold only per pack	item number
Wood veneered quadrant	unfinished French oak	12 x 12 x 2200	6 / pack	1001958
	satin lacquer French oak		Per complete pack only	1001959
Wood veneered scotia	unfinished French oak	12 x 17 x 2200	6 / pack	1001956
	satin lacquer French oak		Per complete pack only	1001957
Wood veneered stair nosing	unfinished French oak	25 x 14 x 2150	10 / pack	1014008
	satin lacquer French oak			1001669
Radiator collar	satin lacquer French oak	Ø 18	per unit	1001643
Wood veneered flat profile	unfinished French oak	4 x 30 x 2200	6 / pack Per complete pack only	1001955
Wood veneered corner profile	unfinished French oak	25 x 25 x 2200	6 / pack Per complete pack only	1001954

Doorsills / Thresholds



"T" bar



doorsill



curved doorsill

		dimensions mm h x l x L	quantity sold only per pack	item number
3 in 1 veneered doorsills				
French oak	dark brown (fauve, walnut)	16 x 54 x 930	10 / pack (or per unit if purchased with wood flooring)	1001976
	unfinished			1001979
	café crème			1020648
	linen (bois flotté, sable)			1001977
	saphir (white oil, shabi chaud)			1001972
	satin (opale, natural oil, miel)			1001980
	topaze			1001978
	tourbe (cuivre)			1001973
	unfinished			1001968
	linen (bois flotté, sable)			1014193
	satin (opale, natural oil, miel)			1014191
	Others species			22 x 50 x 1000
	beech	1001911		
	teak	1001914		

Use the unfinished version plus our oil bottles to match our oiled floors (see page 35).



MAINTENANCE PRODUCTS

ACCESSORIES

Look after your wood flooring!
There's nothing difficult about maintaining a Panaget wood flooring.
All you have to do is take into account its finish (lacquered or oiled) and the way it is used.

Lacquered wood flooring maintenance

		quantity	use	item number
Renovator	for matt wood flooring	1 liter	1 liter / 50 sqm / coat	1001886
	for satin wood flooring			1001887
Cleaner for lacquered wood flooring		1 liter	1 liter / 250 sqm to be diluted with water	1001888
Protect + suitable for kitchens	for matt wood flooring	2,75 liters	12 sqm / liter /coat	1020646
	for satin wood flooring			1020647

Oiled wood flooring maintenance

		quantity	use	item number
Care	natural oil bottle	1 liter	1 liter / 100 sqm when sprayed	1001885
	soap		1 liter / 400 sqm dilution to 10%	1001883
Bottle to renovate oiled floors or for stain unfinished accessories	bois flotté oil	250 ml	ready-to-use 10 sqm/ bottle to renovate oiled floors	1001897
	cabane, grey oil			1013642
cabane, green oil	1013641			
cendre oil	1016596			
chaux oil	1001891			
cuir oil	1001893			
flanelle oil	1001892			
grey oil	1001901			
natural oil	1001903			
other finishes on request	rafia oil			15 linear meter / bottle for staining
	tourbe oil		1001898	
	tufeau oil		1001896	
	white oil		1001902	



After installing the floor, apply a thin coat of Panaget's natural maintenance oil across the entire surface, regardless of the colour of the wood.



THE PANAGET WALL COVERINGS REVOLUTION

BY PANAGET

2 Use exclusive Panaget mounting clip to fix strips to wall.

1 Use exclusive Panaget starter clip to fix first row of strips to THE TOP OF WALL.

Use the right thickness for an ideal insulation and/or soundproof your home.

HORIZONTAL FITTING **VERTICAL FITTING** **DIAGONAL FITTING**



SCAN THE CODE to see picture of the whole range!

MADE-TO-MEASURE DECORATION: GIVE YOUR IMAGINATION FREE REIN.

Coordinate your floor and your walls thanks to our wide collection of wood flooring..



WALL PANELLING - CONCEPT BOIS MURAL

A simple system to fix wall panelling on a metal frame system (such as F530 or S47) or can be also installed using traditional brackets



Format	Species	Finishes	Oil	Profil type	Item number	Photo in the catalogue 2022-2023 or on
Bois mural duo 141	FRENCH OAK	brut de récup	unfinished	2.5 mm straight ship-lap profile	1018613	page 93
		cabane, grey			1013614	page 97
Bois mural 141	FRENCH OAK	bois flotté		2.5 mm ship-lap profile	1001184	page 94
		brushed unfinished	unfinished	2.5 mm straight ship-lap profile	1019825	panaget.com
		brut de récup	unfinished	2.5 mm straight ship-lap profile	1016356	panaget.com
		cabane, green		2.5 mm ship-lap profile	1001179	page 98
		rafa			1001183	page 96
		tufeau		1001182	page 95	
white oil		1001186	panaget.com			

Mounting accessories	Packaging	Use	Item number
Starter clips	box of 10	1 clip / lm	1001665
Mounting clips	box of 100	20 clips / sqm	1001666

Finishing accessories	Dimensions	Quantity sold only per pack	Item number	
Unfinished veneered oak quadrant	12 x 12 x 2200 mm	6 / pack	1001958	
Unfinished veneered oak scotia	12 x 17 x 2200 mm		1001956	
Unfinished veneered oak flat profile	4 x 30 x 2200 mm		1001955	
Unfinished veneered oak corner profile	25 x 25 x 2200 mm		1001954	
Bottles to stain your accessories	cabane, grey oil	250 ml	1013642	
	cabane, green oil		1013641	
	white oil		1001902	
	bois flotté oil		15 linear meter /bottle for staining	1001897
	rafa oil		1001900	
tufeau oil	1001896			

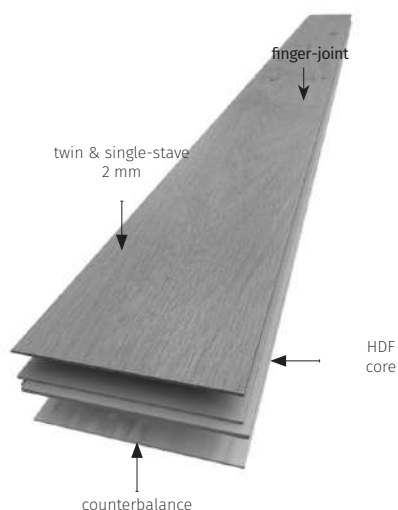

CHARACTERISTICS

Length	2005 mm, twin & single-stave
Width	141 mm
Thickness	10 mm
Core	HDF
Tongue & groove on 4 edges.	

PACKING







Weight / sqm	8.1 kg
Sqm / pack	1.98 (7 planks)
Pack / pallet	30
Sqm / pallet	59.40





CLASSES OF USE

Introduction: classes of use are French standards, provided here for information purposes for countries other than France. In the specification tables, you have seen a class of use number for each type of wood flooring. This indicator involves its restoration and depends on the standard XPB53669. The tables below will help you understand what they mean. You can find the full European class on the internet.

Class of use	Description	Recommended use
Domestic use		
	areas with low or occasional footfall	rooms and corridors in a house with no access to outside
	areas with average footfall	living rooms with no outdoors access to outside and apartment entrance halls
	areas with high traffic	rooms with outdoors access or used for professional business purposes
Commercial use		
	areas with low or occasional footfall	single offices or hotel rooms
	areas with average footfall	libraries, churches and other places of worship, boutiques upstairs or with no direct access to outside, conference rooms
	areas with high traffic	airport lounges, boutiques with direct access to outside, nightclubs excluding actual dancefloors, lecture halls, auditoriums, reception halls upstairs, department stores upstairs, open-plan offices, stairs, IT offices, archives
	areas with very high traffic	multifunctional rooms, classrooms with direct access to outside, company restaurants, museums, public meeting rooms, pharmacies, publishing houses, tobacco shops, reception halls on the ground floor, large cafeterias, airport terminals

NB: The classes of use apply to products after sanding and machining and before surface treatment.

This standard does not apply to the maintenance of the appearance of the product pertaining to:

- the nature of the wood flooring,
- the quality of the surface protection (lacquered or oiled),
- the protection measures applied (sufficient mats at entrances, special protection under furniture and chairs),
- the adaptation of the finished wood flooring to meet the specific requirements of the location (intrinsic durability requirements but also appearance-related requirements),
- or sometimes the adaptation of occupants' way of life to the requirements of the wood flooring in order to allow an appearance-related requirement to be met (ban on heels that make a dent),
- routine care and maintenance carried out,
- restoration work carried out while the floor is being laid.

The UPEC (wear/punching stress/water/chemicals) classes, introduced by CSTB (the French Scientific and Technical Centre for Building), also define the classification of materials. In our case, they are not used because of potential restoration work on the wood flooring. As a guideline, for wood flooring with a wear layer of less than 4.5 mm, the classification would be U2P2E1C0.

Species	hardness class	thickness ≥ 2.5 mm	thickness ≥ 3.2 mm	thickness ≥ 4.5 mm	thickness ≥ 7 mm
Walnut Teak	B: semi-hard wood	21	22	23	31
French oak Maple Beech	C: hard wood	23	31	33	34
Corresponding range of Panaget wood flooring		Orféo click 11 mm Diva 90 click 12 mm Alto 139 click 12 mm Alto 184 click 12 mm Diva 139 click 12 mm Diva 184 click 12 mm Singleplank click 12 mm Herringbone 90	Orféo click 14 mm Diva 139 T&G 14 mm Diva 139 click 14 mm Diva 184 T&G 14 mm Carmen Herringbone 139 Chevron 90 & 139 Ulysse 90	Diva 184 T&G 15 mm Diva 223 T&G 15 mm	Sonate 90 & 140



PRACTICAL ADVICE

COLOURS – NATURAL VARIATION

Each plank is unique thanks to the random natural variations in colour, size, knots and grain: it simply isn't possible to make each one identical. So when you install your floor, you should position the planks in a way that takes into account these features and your own personal taste

Whether it is light or dark, the colour of your floor will change over time. Ultraviolet rays will change the shade of new wood, and if you move a carpet or a furniture, you will notice that the floor underneath is lighter than the surrounding area, though it will take on the colour of the surrounding wood after a few weeks. Walnut wood tends to be particularly affected by this phenomenon.

Wood naturally expands and contracts with changes of temperature and humidity – for example, when your heating system is switched on and off. Don't forget about the expansion gap. Beech and Maple wood floors will contract more than other types of wood. The drying effect caused by heating systems can cause greater shrinkage between the boards.

What is the expansion gap?

This is the free space that needs to be left around the edge of a room, pipes, the bottom of door frames and generally any other fixed point to enable the wood to expand. The expansion gap should be 1.5 mm for every linear metre of wood flooring installed with a minimum gap of 8 mm. Make a 1 cm-deep notch at the bottom of any wooden frames.

OPTIMAL CONDITIONS FOR WOODEN FLOORS

It is important to maintain humidity levels between 40% and 60% and a temperature of at least 15°C when installing the floor and throughout its lifetime. This enhances floor hold and ensures your comfort as well. You should monitor or regulate these levels by using a humidifier or dehumidifier, or by using certain plants. For example, Boston ferns help increase humidity levels whilst cactuses decrease them. These steps help ensure the floor remains even and prevent the wood from buckling or wearing.

If the heating and ventilation are switched off for long periods, for example, in a second home that is often unoccupied, this may cause the floor to warp. This might also happen when the floor is exposed to high temperatures for long periods, such as flooring beside a bay window or in a conservatory.

STORAGE

All premises need to adhere to the conditions specified above. Wood flooring delivered in its original packaging needs to be stored in the rooms where it will be installed or in a clean, dry and sheltered place, away from condensation and rising damp. Wood floor should be protected from the sun and never stored on the floor with underfloor heating switched on or on a still-drying subfloor. You should not open the packs of wooden flooring until the day you plan to install it.

PREPARING THE SITE

Wood floor should only be installed if the following conditions have been met:

- 1 - The windows have already been fitted and the rooms where the floor will be installed meet the specifications detailed above.
- 2 - In a new building, the floor needs to be installed AFTER work on the walls, including painting, wallpapering and mineral rendering, is completed, and the walls themselves are dry.
- 3 - The watertightness of sanitary and heating installations has been checked.
- 4 - The temperature of the premises has to be above 15°C, and the area has to be well ventilated. Taking into account the humidity level to which the flooring is exposed over time, the flooring should not be installed unless the humidity is between 40% and 60%. If this is not the case, all possible measures need to be taken to achieve this level, for example, by heating up the rooms or using a dehumidifier. The humidity level relative to the air (40% to 60%) needs to be constantly maintained.
- 5 - Any risk of a rise in the humidity level of the premises during and after installation needs to be prevented.

SUBFLOOR

The subfloor should comply with the following requirements:

1 - Subfloor humidity:

- Traditional screed: 3% when depth is 4 cm or more.
- Low-temperature underfloor heating: 1.5%.
- Anhydrite (calcium sulphate-based liquid flow screed) screed: 0.5% throughout.
- Wooden subfloor, floorboard subfloor or wood-based panels: 12% measured with the detection pins of a moisture meter.

The subfloor needs to be completely watertight. When flooring is installed directly onto a solid earth base, a damp-proof membrane should be placed underneath. As a guide, you should allow at least 10 days drying time per cm of screed thickness. This period should be increased by 50% in wet weather.

2 - Levelling tolerances

An uneven screed is only acceptable within the following tolerances:

- rise of 5 mm maximum over 2 m.
- rise of 1 mm maximum over 20 cm.

If these conditions are not met, you need to use a levelling compound. Never use glue to compensate for irregularities in the subfloor.

MAINTAINING WOOD FLOOR HUMIDITY LEVELS

It is vital that the humidity levels of engineered and solid-wood floors are maintained at every stage, including once installation is completed. The planks are made from wood that has been dried for six to eight weeks until a humidity level of around 9% for solid wood and 7% for engineered wood is obtained. This humidity level needs to be constantly maintained.

QUALITY

Our wood floors are subject to continuous and strict quality controls. When unpacking the planks, if you notice any defects or anomalies that may negatively impact the floor's appearance when installed, we advise you to IMMEDIATELY halt the process and contact your retailer. We cannot be held responsible if you fail to respect one or more of these recommendations.

VARIABLE LENGTHS

The majority of planks from our ranges are delivered in packs of random lengths. We recommend to open several packs when installing the floor in order to mix and match different lengths and hues.

IMPORTANT INFORMATION

For glued installation: glue should be spread across the entire surface of the wooden floor when sticking it down. We do not guarantee beaded application.

Bead adhesive is not suitable for use on underfloor heating/cooling systems. Bead adhesive is only suitable for glueing tongue-and-groove wood floor to the floor in an English or brick bond installation.

For floating installation: subfloors with a thickness of more than 3 mm (excluding fibreboard panels) or those that are highly compressible should be avoided. For this reason, you cannot install the floor on top of carpet.

THE GOLDEN RULES

The inherent nature of wood means a certain number of precautions need to be taken during each stage of floor installation: before, during and after installing the floor. They are outlined above, and can also be found on each package (floor installation guide with images on the back) as well as in the official DTU 51-2 "Glued Wood Floors" and 51-11 "Floating Wood Floors" guidelines. All of the documents related to your product (technical specification sheets, maintenance instructions, etc.) as well as practical information and advice on installing floors can be found on our website: www.panaget.com

For further technical information, get it with us via phone or our website.



INSTALLATION ON LOW-TEMPERATURE UNDERFLOOR HEATING

Underfloor heating and cooling systems require special precautions in addition to those on the previous page.

Before you start working, check with your retailer that the flooring is compatible with your system. We do not recommend using jatoba, or maple species in such situations, and the heat resistance of floor coverings and any intermediate layers (such as acoustic underlays) should not exceed 0.15 W/m²K.

Subject to these conditions, the surface temperature of finished floors should not exceed 28°C (82°F).

We advise against using carpets and low-lying furniture, as they can significantly affect the system's performance.

Hydronic underfloor heating

You must comply with all provisions of DTU 65.14, "Installation of hot-water floor heating."

This type of system allows the floor to be floated with an underlay. If you glue-down the full surface, you must use Presto PM glue.

Main installation requirements:

- The thickness of the covering layer on top of the heating system needs to be at least 5cm.
- The water temperature should not exceed 40°C (104°F)
- The heat output should not exceed 95 W/m².
- The system needs to be carefully regulated, particularly when it is switched on for the first time, but also throughout its working life, to ensure this temperature is not exceeded.

Starting up the system:

- The subfloor will already have dried naturally, but the room also needs to be preheated for at least three weeks before the flooring is installed, regardless of the time of year.
- Turn off the heating 48 hours before installing the wooden floor.
- Then switch it back on no sooner than a week after you have finished installation, increasing it by 5°C (41°F) per day until it reaches the right temperature.

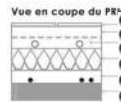
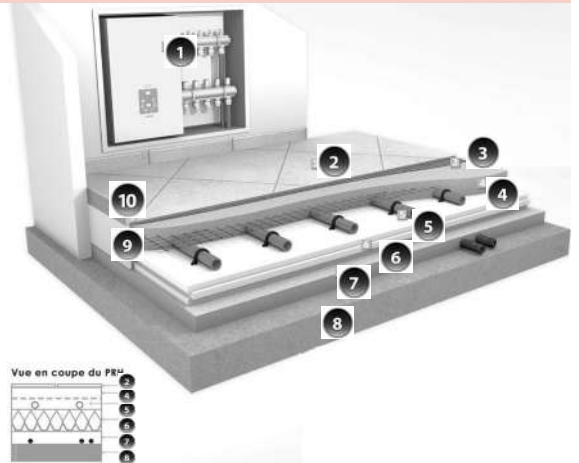

- | | |
|---|----------------------------------|
| 1 - Manifold | 6 - Isolant |
| 2 - Floor covering | 7 - Mortar bed if necessary |
| 3 - Floating with underlay or fully glued | 8 - Coreing slab |
| 4 - Floating screed | 9 - Edge band with sealing skirt |
| 5 - Cross-linked polyethylene | 10 - Skirting board |

Electric underfloor heating

Heated floors with electric cables buried in concrete must comply with NF C 32-330, and be installed in accordance with NF P 52-302 (formerly DTU 65-7).

Electric underfloor heating consisting of a heating cable covered with a screed or slab must comply with CPT Electric underfloor heating (CSB 3606).

The system also allows the floor to be floated with an underlay. If you glue-down the full surface, you must use Presto PM glue.

Main laying requirements:

- The covering layer above the heating elements should be at least 5cm thick.
- The heat output should not exceed 95 W/m².
- The temperature needs to be carefully regulated, particularly when the system is switched on for the first time, but also throughout its working life, to ensure that it does not rise too quickly.

Starting up the system:

- Electric radiant systems need to be started for the first time by an electric heating engineer.
- The subfloor will already have dried naturally, but the room also needs to be preheated for at least three weeks before the flooring is installed, regardless of the time of year.
- Turn off the heating for 48 hours before installing the floor.
- Then switch it back no sooner than a week after you have finished installation, increasing it by 5°C (41°F) per day until it reaches the right temperature.

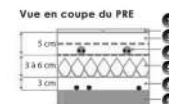
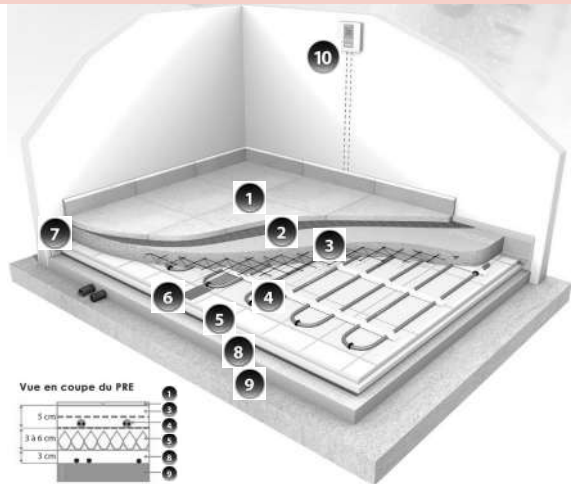

- | | |
|---|-----------------------------|
| 1 - Floor covering | 6 - Adhesive |
| 2 - Floating with underlay or fully glued | 7 - Edge strip |
| 3 - Floating screed | 8 - Mortar bed if necessary |
| 4 - Heating cable | 9 - Coreing slab |
| 5 - Insulation | 10 - Room thermostat |



LAYING ON A REVERSIBLE FLOOR HEATING/COOLING SYSTEM

You must glue the full surface to the floor using a PM glue and without an underlay (see glueing, page 39), and you must also comply with DTU 65.14, "Installation of hot-water heated floors" and CPT "Low-temperature water-heated floors" (CSTB 3164).

Main installation requirements:

- The system must ensure that heat is evenly distributed across the surface.
- Fluid temperatures must be controlled by automatic probes to prevent underfloor condensation.
- The circuit must limit the fluid output temperature to between 18 and 22°C depending on the geographical region (see table below). The system installer must comply with this requirement.
- Heat emissions must not exceed 95 W/sqm.
- In summer, individual room thermostats should not be set below 22°C. The cooling system will not switch on until the ambient temperature is 25°C or less.

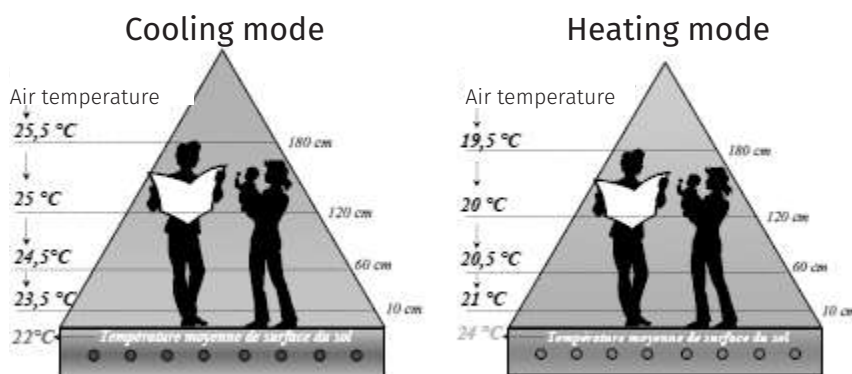

Starting up the system:

- The subfloor will already have dried naturally, but the room must also be preheated for at least three weeks before the flooring is installed, regardless of the time of year.
- You should then switch off the heating 48 hours before installing the flooring, and switch it back on three days after you have finished doing so. Then increase it by 5°C per day until it reaches the right temperature.



FITTING INSTRUCTIONS

LAYING INSTRUCTIONS FOR PANAGET WOOD FLOORS

Wondering how to install your wood flooring?
Looking for advice to choose your floor and get maintenance recommendations?

Visit our **tips page** on www.panaget.com and watch our **videos**.

Panaget floors won't have any secrets for you!



SCAN THE CODE
to watch our videos or join us on the Panaget Parquet Youtube channel.



Floating installation, click Unifit

Easy and fast, this click is also compatible with the Just1click! Suitable for most supports.

----> Singleplank 139, Alto 139x1210 and Alto 139-184x2010



Floating installation, 2beclick

Easy and ultra-fast this new generation click! Suitable for most supports.

----> Orféo 139 / Diva 90, 139 and 184



Floating glued installation

Assembly by gluing tongue and groove. For engineered planks.

----> Diva 139, 184 and 223 / Carmen / Herringbone / Chevron



Glue-down installation

Required for wet rooms, reversible heated floors, all solids and large trays. Wanted for sound comfort.

----> Sonate / Ulysse



Installation of Concept Bois Mural

Panaget's ingenious patented installation technology. This new wall cladding in oak or walnut lets you change the whole look of a room in a few minutes.





DISCOVER THE PANAGET RANGE

Various communication tools are available to discover our range: the website www.panaget.com, the **catalogue 2022-2023** as well as **brochures** highlighting our new products or specific ranges. You can also use **IMAGINE BY PANAGET**, the Panaget **visualizer**.

Since **December 2020**, use **IMAGINE BY PANAGET !**

What is it ?

A tool accessible from your smartphone, tablet or computer allowing you to visualize your interior with Panaget wood flooring.

Take a picture of your interior and choose the Panaget wood floor you like!

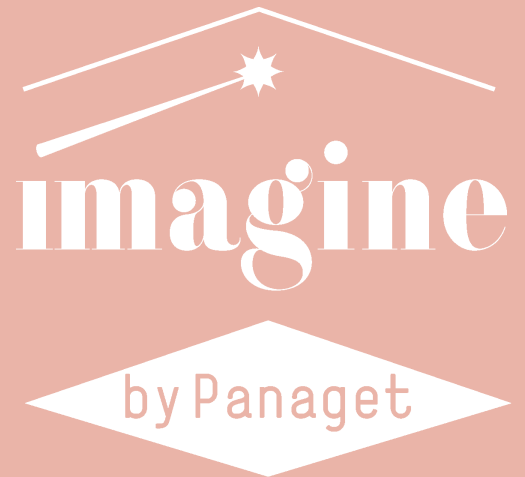

Downloadable **2022-2023 catalog** online:
Discover and share it by mail or on social networks directly from our page.

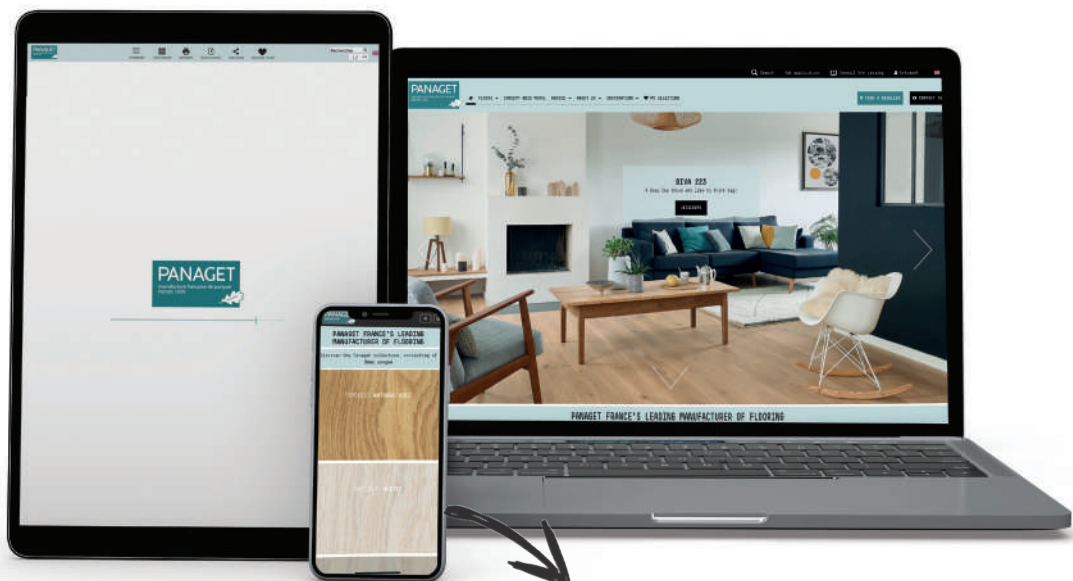

For even more news,
follow us !

More than **177 references**
sorted by color!
Access each product and
technical sheet.

TECHNICAL LIST 2022 www.panaget.com



WOOD FLOORS MAINTENANCE

Maintaining wood floors is becoming increasingly simple!

State-of-the-art finishing techniques ensure more and more efficient protection against everyday wear and tear, such as scratches and stains. However, it is still important to protect and clean your wood floor to ensure it retains its original appearance over the years.

For maximum durability, your Panaget flooring should only be subject to normal levels of wear and tear and should be properly maintained. This means taking precautions against damage caused by abrasive particules such as sand and gravel, as well as chair and table legs and castors on the bottom of armchairs, TV stands, etc. How long your floor lasts will depend on how well you look after it.

Steam cleaners and warm or lukewarm water should not be used to clean wood floors.

Protection and prevention:

Various problems can result from specific forms of use and lead to unsightly damage to the wood floor.

Wood floor maintenance starts with the use of a rug at the doorway to the room as well as an absorbent doormat to capture any abrasive particles (sand, gravel, etc.).

Make sure to avoid any risk of unnecessary wear caused by unsuitable castors on pieces of furniture:

- Replace narrow plastic castors with wider rubber versions.
- If possible, place a rug or a translucent protection sheet under any armchairs or moveable furniture
- Cushion the bottom of tables and chairs with felt glides.

Don't forget that wood is a natural material and however hard it is, it can still be dented (by walking on it in high heels, for example).

Maintaining the humidity levels of wood floors:

To enhance floor hold and ensure your comfort, relative humidity should be kept between 40% and 60%, with an ambient temperature of 15°C (59°F).



Consult the Advice section of our website to discover all the tips for maintaining our wood floors.



How to protect my wood floor ?



Maintain my lacquered wood floor



Maintain my oiled wood floor

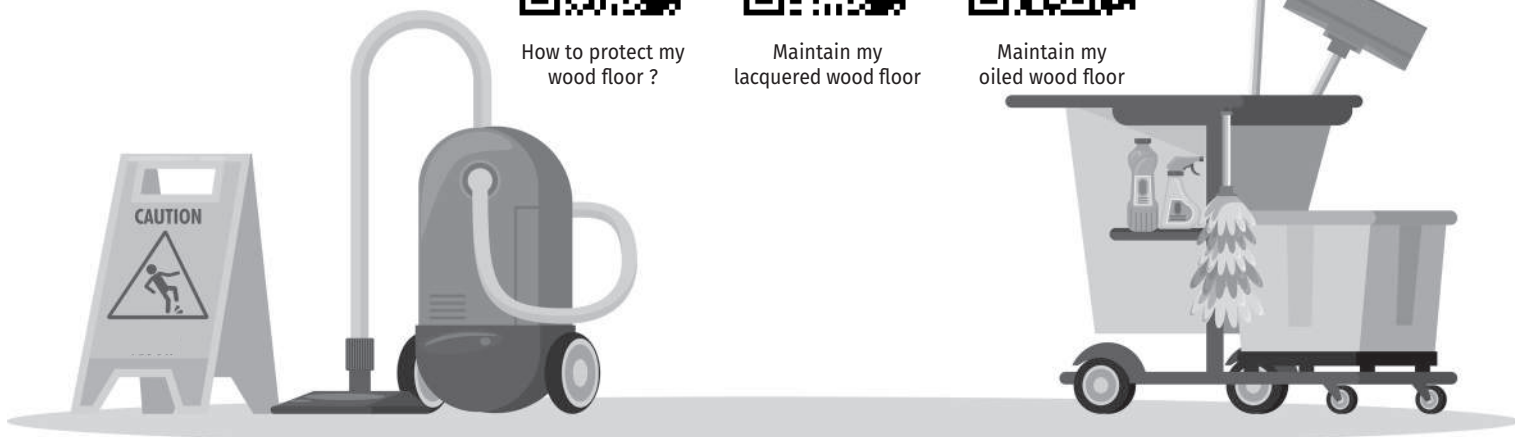



WOOD FLOORS MAINTENANCE

Lacquered wood floors maintenance



Maintenance:

- Dust the floor on a daily basis using a vacuum cleaner.
- In case of stains or ring marks, mop the floor with a wrung-out microfibre floor cloth, then dry it with kitchen roll. Cold water should always be used to clean the floors, no more than once a month. Use a neutral cleaning product (cf. page 35) if necessary, but avoid using any abrasive products or those containing silicone.
- For brushed wood floors, we recommend occasional cleaning with a soft nylon brush, brushing in the same direction as the woodgrain.

Protection:

Following your own assessment of lacquer wear and tear, a protective matt, satin or metallic protective coating (Metalisant) can be applied to restore the original appearance of the lacquer. Make sure to vacuum up any dirt before applying a metallic coating and follow directions for use.

Oiled wood floors maintenance



Panaget's oiled finish is an impregnation oil that helps conserve the wood's natural appearance. The formula offers effective and long-lasting protection against stains and marks. To ensure your wood floor keeps its appearance over the years, it is very important to carry out the appropriate maintenance and follow the instructions below. Please note that certain cleaning products may contain wax or other unsuitable substances that can damage the surface of the wood. For this reason, we recommend using Panaget products.

After installing the floor, apply a thin coat of Panaget's natural maintenance oil across the entire surface, regardless of the colour of the wood.

Monthly maintenance:

- Oiled wood floors should be regularly dusted (with a broom or vacuum cleaner).
- To get rid of stubborn stains, use Panaget's natural soap.
- Always use cleaning tools that have been well wrung out and are not dripping (microfibre or sponge mops).
- Wood floors should only be cleaned with cold water.

Annual maintenance once or twice a year, depending on traffic:

Ensure the wood floor is clean and free of dust, then:

Apply Panaget maintenance oil, and wipe with a clean, dry cotton cloth, until full penetration of the oil.

Simple and sensible, regular maintenance regenerates the protective coating and preserves the natural, warm appearance of oiled wood floor.

Whichever finish you choose, caring for your wooden floor is extremely simple: all you need to do is regularly dust it with a damp cloth to remove soiling. Oiled wood floor calls for a little more care, for which reason we recommend treating it with a coat of maintenance oil regularly to ensure it keeps its shine.

Partial renovation can be carried out in areas where there is particular damage (cigarette burns, impacts, deep scratches, etc.). Lightly take the gloss off the area using steel wool or sandpaper, until the damage has been removed.

In a container, mix the Panaget repair oil for at least three minutes, to ensure a fully consistent substance.

Use this mixture to reimpregnate the zone with a small brush or cloth in successive thin coats, until the touch-up cannot be seen.

The drying times for two-component Panaget repair oil are as follows:

Time required before recovering: 8 hours

Definitive curing: up to 6 days

L'EXPOZ'

by Panaget

DISPLAYS TO COMBINE ACCORDING TO YOUR DESIRES...



PREFER OUR ARRANGEMENTS EXPOZ' XS...

compositions comprising from 2 to 4 displays for the presentation of 16 to 34 samples.



Panaget can provide you with this display system for showcasing its references. Purposefully designed to be versatile yet very understated with some smart finishes, it can easily slot into any showroom to advertise the Panaget brand. The display system goes hand in hand with our catalogue and website, showcasing Panaget wood flooring and wall panellings in their best light and helping you boost sales. Our display system, designed perfectly to sit on its own, can also be doubled up to form coherent, smart-looking units.



L-shaped display system >

14 sqm



Linear display system >

6.80 m long

L'EXPOZ,



U-shaped display system >

14.5 sqm



Two-sided, back-to-back display system > 8 sqm

A set of our 72 standard products, mirroring exactly what can be found in our catalogue and on our website, to give customers a better overview of our entire range.



OUR 30 YEARS GUARANTEE

30-year contractual guarantee regarding the manufacturing of the wood flooring and wall panelling (excluding surface condition):

Thank you for choosing a high-quality product made in France. The manufacturing of our wood flooring and wall panelling is contractually guaranteed for 30 years, in line with normal usage of said products.

This 30-year contractual guarantee shall take effect on the date that appears on the invoice or proof of purchase, which should be kept with the corresponding 30-year guarantee certificate, with the batch number inscribed under the strips or on the inspection stamp.

Legal guarantees:

Independently of the contractual guarantee, our products are guaranteed against any lack of conformity and hidden defects, under the conditions set out in Articles L 211-4 et seq. of the French Consumer Code and Articles 1641 to 1649 of the French Civil Code.

[Article L. 211-4 of the Consumer Code

The seller must supply a product that complies with the contract, and is liable for any defects existing when it is delivered or resulting from packaging or assembly or installation instructions for which it is directly or indirectly responsible under the contract.]

[Article L.211-5 of the Consumer Code

To comply with the contract, the product must:

1: be suitable for the use one would normally expect of such an item and, if appropriate,

- comply with the seller's description and be of the same quality as any sample or model presented to the buyer;
- be of a quality which the buyer could justifiably expect given public statements made by the seller, the manufacturer or its agent, particularly in terms of advertising and labelling, or;

2: Have the agreed characteristics and be suitable for any specific use required by the purchaser and notified to and accepted by the seller.

[Article L217-12 of the Consumer Code

the right to take action concerning any lack of conformity shall lapse two years after the item is handed over.]

[Article L217-16 of the Consumer Code

Where the purchaser asks the seller, during the validity of the commercial guarantee that was granted to it when an item of moveable property was purchased or repaired, for restoration covered by the guarantee, any period lasting at least seven days during which the goods are out of use shall be added to the remaining duration of the guarantee.

That period shall start to run as soon as the purchaser requests intervention or makes the item in question available for repair if that is later than when the request for intervention was made.]

[Article 1641 of the Civil Code

The seller shall be liable for any hidden defects in an item sold that render it unsuitable for its intended use, or reduce its usefulness such that the buyer would not have acquired it, or would have paid a lower price, if they had known about it.]

[Article 1648, paragraph 1 of the Civil Code

The buyer must claim for hidden defects within two years of discovering them.]

Panaget shall not apply said contractual or legal guarantees:

- to downgraded or clearance Goods (Ecofloor and Utility grades);
- goods not paid for in full;
- to apparent defects not notified before or during the laying of the relevant Goods;
- to damage that is deliberate or caused by fair wear and tear, negligence, incorrect storage, an accidental act, an unplanned event or a case of force majeure;
- to goods not laid, used or stored in compliance with the recommendations contained in the corresponding User Guide or printed on the packaging or in our technical list;
- in the event of inadequate maintenance;
- in the event of a difference in appearance compared with that of samples which have not undergone the same exposure to UV radiation (patina);
- in the case of laying in rooms where water is in regular use (bathrooms, kitchens, etc.) unless the wood flooring or wall panelling is designed specifically for this purpose;
- if the product is installed in locations subject to significant changes in humidity, such as saunas, steam rooms and swimming pools;
- to defects related to failure to comply with the climatic conditions laid down and which would have been avoided if the humidity of the air had been regulated by the use of a humidifier or a dehumidifier and appropriate ventilation;
- if the product has been modified and/or repaired by you or a non-approved third party, with the exception of minor repairs carried out as part of the maintenance process;
- to wear due to penetration (stiletto heels, etc.) of the wood and damage to the finish (lacquer, oil, colour, etc.) related to the use of the room.

Furthermore, said guarantees are limited to replacing defective Goods by supplying identical or similar goods and excludes the costs of lifting a laid floor, laying another floor and any damages and interest.

A reminder of certain installation/laying, usage and maintenance recommendations:

- The goods must be installed and laid in a way which meets all the implementation and humidity conditions as set out in our recommendations included with the Goods in question and in accordance with the implementation DTUs (French building regulations).
- The conditions required for installation in a Public-Access Building (PAB) must be known and fulfilled at the time of purchase.
- Maintenance must be carried out with the appropriate products.
- It is the purchaser's responsibility to maintain the ambient air in its premises at between 40% and 65% humidity and, where applicable, to regulate it using a humidifier or dehumidifier.
- Laying wood flooring or wall panelling in rooms where water is in regular use (bathrooms, kitchens, etc.) requires the use of an appropriate product (Ulysse) and/or requires measures to be put in place in order to prevent any risk for said wood flooring or wood panelling.
- The product must not be installed in wet areas such as shower trays and swimming pools.
- Wood flooring guaranteed for laying on floors with "low temperature" underfloor heating and/or for laying on floors with underfloor heating and cooling must be laid in accordance with the recommendations indicated in our current technical list or on the website.

Submitting a claim:

- If you encounter a problem, please stop installing our wood flooring or wall panelling immediately and consult us. If you wish to claim under the 30-year guarantee, please inform us by sending the corresponding guarantee certificate and the purchase invoice by registered mail with delivery confirmation, quoting the number on the back of the strips or the inspection stamp
- We may wish to inspect the defective product onsite.
- If we carry out an inspection and find that your claim is justified, our liability is limited to replacement of the defective product with an identical or similar one, and excludes the costs of lifting a laid floor, laying another floor and any damages and interest.
- If we repair the product under the guarantees mentioned above, and you are unable to use the product for seven days or more as a result, the remaining guarantee period will be extended by the same amount of time (Article L. 211-16 of the Consumer Code).

Our floor and wall coverings are made with a great deal of care and professional expertise, and this 30-year guarantee represents our commitment to your satisfaction.



GENERAL TERMS OF SALE

1 - GENERAL PROVISIONS

These terms and conditions are written in French in their original version, which alone shall be deemed authentic (middle grade) and shall take precedence over any other version translated into a foreign language.

These general terms and conditions shall apply in full to all sales of Goods (wood block flooring and accessories) made by Panaget to professional Clients starting on 01/01/2022. They are the fundamental and determining conditions and shall take precedence over any general conditions of purchase and any other documents issued by the Client, whatever the terms. Furthermore, any order sent to Panaget implies unconditional acceptance of Panaget's prices and these general terms and conditions.

2 - APPLICABLE LAW - JURISDICTION

Any question concerning these general terms and conditions, as well as the contracts to which they apply, shall be governed by French law.

In the event of a dispute, any difference concerning these general terms and conditions, as well as the contracts to which they apply, shall be dealt with only by the Trade Court of the town where Panaget has its registered office, even in the case of a summary ruling, proceedings against a guarantor which may take the form of giving third party notice, a summons or a plurality of defendants.

3 - ORDERS

Sales agreements are concluded validly only after written confirmation or the start of execution by Panaget of the corresponding orders. However, any order commits the Client as soon as it is issued regardless of the bearer or the signatory. Any amendment made by Panaget at the time it confirms the order shall be deemed accepted in full in the absence of a written refusal by the Client within two working days starting from the date of its communication and at the latest before its performance.

No order may be cancelled and/or assigned without Panaget's agreement.

4 - GOODS

They shall comply with the technical specification or, alternatively, with current AFNOR standards. The quota for the Goods (wood flooring and wall panelling) will be set per sqm.

5 - RESERVED TITLE

GOODS ARE SOLD WITH TITLE RESERVED UNTIL FULL PAYMENT HAS BEEN MADE. IN THIS RESPECT, PAYMENT MEANS CLEARED FUNDS SHOWING IN PANAGET'S BANK ACCOUNT REPRESENTING THE PRICE OF THE GOODS, ANY CHARGES RELEVANT TO THE ORDER AND ANY INTEREST OWING.

In the event of non-payment, even partial, by the Client of a debt on the due date, Panaget shall be able specifically to claim the cost price of the unpaid Goods or recover same at the expense and risks of the Client, Goods in stock on the Client's premises being presumed as those unpaid.

Panaget shall retain any instalments paid as compensation, without prejudice to any other claim for reparations.

Modification and/or repacking of Goods still unpaid is prohibited. The Client may not under any circumstances pledge or mortgage Goods still unpaid, nor grant any securities over the latter. Finally, the Client may only resell Goods to which title is reserved for the normal needs of its business.

6 - DISPATCH - DELIVERY

61. For any order to be delivered in France, Panaget shall be deemed to have discharged its despatch & delivery obligation as soon as the Goods are delivered to the Client's registered office or to any other delivery point agreed with

However, the Client may, at its discretion, elect to collect the Goods personally at its own expense, risks and perils. It must inform Panaget of this at the time it places the order. The Goods shall be deemed delivered at the time they are supplied to the Client in Panaget's factories, stores or warehouses, or at any other place which the latter shall nominate. However, in this case, no price reduction will be made.

62. For any order to be delivered abroad, unless stipulated otherwise, the Goods will be delivered "ex works" (EXW, Incoterms ICC 2010).

63. Lead times are given for information only and failure to meet them shall not under any circumstances cause cancellation of the order or payment of compensation. Whatever the reason, the Client may not protest against any delay in delivery if it is not up to date with its obligations to Panaget, in particular as regards payment, or if Panaget was not in possession in good time of any specifications and/or information needed for the delivery.

7 - TRANSFER OF RISKS

Notwithstanding the reserved title clause mentioned in article 5 above, the Goods shall be deemed in the Client's custody as from the date of their despatch and delivery as set forth in article 6 above. Again, as from said despatch and delivery, the Client alone shall bear the risks which the Goods might suffer or cause, for any reason whatsoever, even in the event of force majeure, accident or act by a third party.

8 - COMPLIANCE - ACCEPTANCE

It is essential that the Client confirms compliance of the Goods (condition, absence of any apparent defect, quantity, etc. at the time of their receipt, in the presence, where relevant, of the

carrier; any costs or risks related to checking the Goods being the Client's responsibility.

If the Goods are collected by the Client, any reservation or dispute concerning an apparent non-compliance of the Goods must be recorded on the delivery note and confirmed to Panaget by registered letter with return receipt, within three days as from their collection.

Should Panaget arrange for the Goods to be shipped to the Client's premises, any reservation or dispute concerning an apparent non-compliance of the Goods must be recorded on the consignment note or CMR and confirmed to the carrier and to Panaget by registered letter with return receipt sent within 3 days (excluding public holidays) following taking delivery of the Goods. Failing compliance with these conditions, the Goods will be deemed compliant and Panaget's liability will not be challenged accordingly, the Client being held liable for any damage suffered by Panaget as a result of failure to comply with this procedure.

The Client will have to prove the existence of any shortfalls, defects and/or discrepancies relating to the Goods.

The appearance of any samples shall reflect as far as possible that of the Goods. Again, no claim for trivial differences of appearance with samples will be entertained.

9 - RETURNS - RECOVERY

No return of Goods will be accepted without express and prior agreement from Panaget.

Returned Goods must be in perfect condition, shall be returned in their original packing or packaging and shall not have been used and/or modified.

Any return accepted by Panaget shall generate, at the company's discretion, an exchange or a credit to be used against a later purchase, after qualitative and quantitative checking of the returned goods, no compensation being payable for any reason whatever.

In the event that Panaget agrees to take back Goods with no proven defect, said Goods shall be returned to Panaget by the Client at its own risk and expense, following the application of a discount of 20% on their invoiced price.

10 - GUARANTEES

Without prejudice to any applicable mandatory legal guarantees, Panaget shall contractually guarantee the design quality of its wood flooring and wall panelling for 30 years in line with normal usage. The duration of the guarantee shall be mentioned on each Good and shall apply as from resale to the users.

However, Panaget shall not apply the guarantee to:

- downgraded or clearance Goods;
- goods not paid for in full;
- apparent defects not notified before or during the laying of the relevant Goods;
- damage that is deliberate or caused by fair wear and tear, negligence, incorrect storage, an accidental act, an unplanned event or a case of force majeure;
- goods not laid, used or stored in compliance with the recommendations contained in the corresponding User Guide or printed on the packaging or in our technical list;
- maintenance not in accordance with Panaget recommendations
- a difference in appearance compared with that of samples which have not undergone the same exposure to UV radiation (patina);
- laying in rooms where water is in regular use (bathrooms, kitchens, etc.) unless the block flooring is designed specifically for this purpose;
- if the product is installed in locations subject to significant changes in humidity, such as saunas, steam rooms and swimming pools;
- faults related to failure to comply with the climatic conditions laid down and which would have been avoided if the humidity of the air had been regulated by the use of a humidifier or a dehumidifier and appropriate ventilation;
- cases where the Client or the user has personally repaired defective Goods or has had them repaired by a third party (other than minor repairs for maintenance purposes);
- wear due to penetration (stiletto heels, etc.) of the wood and damage to the finish (lacquer, oil, colour, etc.) related to the use of the room.

Furthermore, any applicable guarantee is limited to replacing defective Goods by supplying identical or similar goods and excludes the costs of lifting a laid floor, laying another floor and any compensation.

11 - PRICES

Goods will be billed at the prices extant on the date the relevant order was made.

Goods produced to a specification are always sold and billed against the quotation, which is issued for a term of two months

Carriage will either be paid by Panaget or billed as an extra, under the conditions laid down and at the price current on the day of the corresponding order by the Incoterm agreed between the Parties.

Unless specified differently, charges, taxes and any excise duties due shall be paid by the Client.

12 - PAYMENT - PROCEDURES

12.1. As regards national sales, Goods are to be paid for in Euros at Panaget's registered office by cheque, bank transfer or commercial paper:

- cash for any initial order;

- within 30 days of the invoice date for subsequent orders providing there is credit insurance.

If payment is made by bill of exchange against a statement of account, the Client must return the accepted bill within 8 days. We do not grant discounts for early payments.

12.2. Concerning international sales, unless agreed differently, payment shall be made in cash on delivery in Euros, by SWIFT bank transfer or even, at Panaget's simple request at the time of accepting the order, by letter of credit under the conditions specified by the latter. We do not grant discounts for early payments.

12.3. In any event, if there is a risk of the Client becoming insolvent or if there will be collection issues, and/or for any other similar reason, Panaget may demand any guarantee, a deposit, a reduced payment period and/or a payment in cash before executing orders.

Payment shall be deemed made on provision of the funds to Panaget, i.e. on the day that the amount is credited as cleared funds to one of the latter's bank accounts.

13 - PAYMENT: LATE PAYMENT OR DEFAULT

Late payments will be subject to penalty interest at the European Central Bank rate plus 10 basis points from the due date until payment is made, in accordance with article L441-6 of the French commercial code.

Furthermore, any delay in payment will entail de jure suspension of the performance of any outstanding orders, removal by way of a penalty of the Client's rights to any price reduction and the immediate calling in of any debt owed to Panaget.

If you fail to make payment within 15 calendar days of being sent a first reminder, we may cancel your order, and any other unpaid orders and/or contracts, regardless of whether these have been or are being fulfilled, and of whether the payment is late. Panaget will then retain any deposits which may have been paid, without prejudice to any other compensation and any other costs.

Payment of the price shall be made on provision of the cleared funds to Panaget and will be made by the Client at Panaget's registered office or at the place nominated by the company.

You may not offset any amounts which we owe you against all or part of a payment to us. We may set a credit limit, or reduce your existing limit, or change our terms of payment, at any time.

The Client will have to refund any expenses incurred by failure to pay on the due date entailing a return of any bills of exchange, unpaid cheques, and by recovery of the sums owed, including fees for bailiffs and solicitors.

We may charge an automatic fixed penalty of 40 euros to cover our collection costs as specified in article L441-6 of the commercial code, and may also pass on any additional collection costs which we incur, subject to the provision of supporting documents.

14 - FORCE MAJEURE

Cases of force majeure concerning Panaget's obligations are deemed those events over which it has no control and which it could not reasonably be expected to anticipate, insofar as their occurrence makes discharging its obligations more difficult or more burdensome. This shall also apply in all circumstances even if these are not covered by the aforementioned definition, in particular cases of war, explosion, acts of vandalism, riots, civil commotion, acts of terrorism, machine failure, fire, storm, water damage, strike, lock-out, acts by government, embargo, lack of raw materials, supply problems, changes to the regulations applicable to the Goods, occurring in Panaget's factories and/or premises and/or on the premises of suppliers and/or service providers used by the company.

15 - PERSONAL DATA

The Parties undertake to comply with the regulations relating to the collection and processing of personal data, including Regulation (EU) 2016/679 of the European Parliament and of the Council dated 27 April 2016 (the "GDPR"). As the data controller, Panaget processes its customers' data electronically to manage orders. Personal data collected in this context (customer's company name, first name and surname of the customer's contact person, email address, business telephone or fax number) is strictly necessary to fulfil the order, delivery, billing and collection. This data is kept during the commercial relationship and for the duration of the legal retention period. Recipients of the data include our customer services, sales, billing and collection departments, and our subcontractors responsible for delivery. Customers have the right to access, rectify, erase and object to the processing of their personal data by sending an email to dpo@panaget.com or by writing to PANAGET - Data Protection Officer - 3 Rue d'Orgères, 35230 Bourgbarré. Customers who feel that Panaget has failed to respect their rights and adequately address their complaints may complain to the French Data Protection Authority (Commission nationale de l'informatique et des libertés or CNIL).

LIGHT WHITES			SUBTLE GREYS						ELEGANT BROWNS					
WHITE OIL	LINEN	TUFEAU	CAFÉ CRÈME	RAFIA	GREY OIL	CENDRE	TOPIA	FLANELLE	ARGILE	HABANO	CUIR	FAUVE	CUIVRE	TOURBE
														
														
	Diva 90-12 Diva 139-14													
	Diva 139-12 Herringbone 90 (mixed Cl/Auth)	Diva 139-14 Diva 184-15 Herringbone 90 (mixed Cl/Auth)	Chevron 139	Diva 184-15				Diva 184-15	Diva 223-15	Herringbone 90 (mixed Cl/Auth)	Diva 90-12 Diva 139-12/14 Diva 184-12/14/15			
			Alto 139*1210								Orfeo 139-14			
Diva 139-12 Diva 184-14	Diva 139-12 Diva 184-12/14 Sonate 140-14	Diva 139-12 Diva 184-12/14 Chevron 90	Diva 139-12 Diva 184-14 Sonate 140	Diva 139-12 Diva 184-12/14	Diva 184-14	Diva 184-14	Diva 184-14	Diva 184-12/14	Diva 184-14	Diva 139-12		Diva 139-14 Diva 184-14		Diva 184-14
		Diva 139-14 Diva 184-14 Herringbone 139						Herringbone 139			Diva 139-14 Diva 184-14 Sonate 140-14			Diva 184-14
					Diva 139-14									
	Single plank 139													
		Diva 139-12									Diva 139-12 Diva 184-14			

Available only in Flamed beech, Diva 139 / 14 mm click



imagine

by Panaget

*Panaget wood flooring
room visualizer,
redecorate your interior!*

www.panaget.com

PANAGET
manufacture française de parquet
DEPUIS 1929

**IMAGINE BY PANAGET,
the wood flooring visualizer with
more than 100 references.**

TRY IT!



PANAGET

manufacture française de parquet
DEPUIS 1929



une société du **groupe Bouyer Leroux**

www.panaget.com

3, rue d'Orgères 35230 Bourgbarré - France

Tél. | 0033 2 99 05 77 77

Fax | 0033 2 99 57 73 55